

4MP Outdoor PoE Spotlight Camera (ADC-VC730P) - Installation Guide

Pre-Installation Checklist

- ADC-VC730P camera (included)
- PoE switch
- ADC-V730 AC power adapter (required for non-PoE connections) (sold separately)
- An Ethernet / Cat5e cable
- Router with broadband Internet connection (Cable, DSL, or Fiber Optic) and an open Ethernet port
- A computer or mobile device with Internet access
- Username and password for the Alarm.com account to which the camera is added

In the box

Expand all

What's included [^]

ADC-VC730P camera

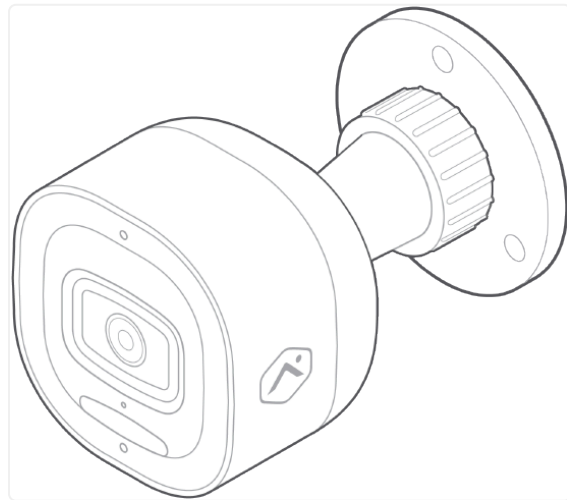

Installation sheet with QR code and drill template

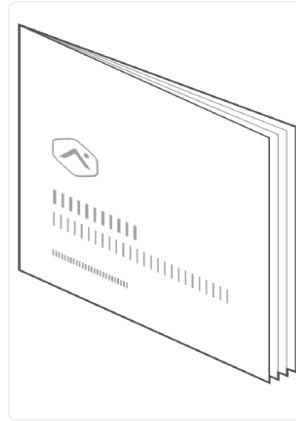

Wall anchors & screws (3)

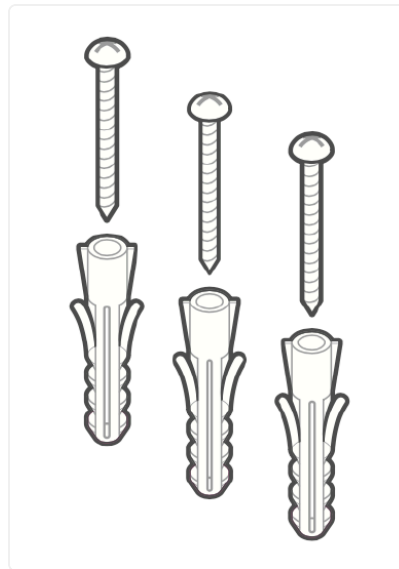

Rubber plug

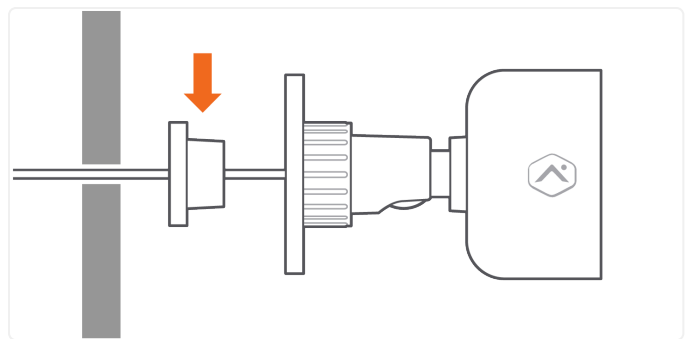

Important: A rubber plug has been included with the ADC-VC730P at the base of the mount. This rubber plug should only be used if the device is being mounted directly over a hole in the wall. The rubber plug will provide a seal to prevent water from entering the hole in the wall behind the camera. In all other installations, please remove the rubber plug. Removing the rubber plug will allow you to route the power cable through the mouse hole without bending or breaking the cable.

Overview

1. Ambient Light Sensor
2. Microphone
3. Spotlight
4. Status LED
5. Reset Button
6. SD Card Slot
7. SD Card Door
8. Speaker

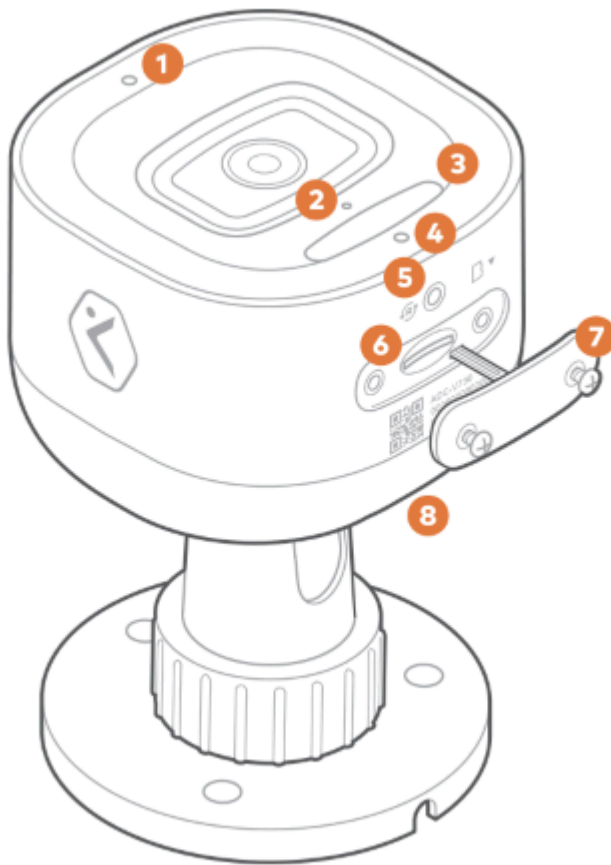

Installation

For information about general video installation and maintenance guidelines, see [Video Installation Best Practices](#).

Enroll the camera to the customer account

Choose the appropriate installation wizard (i.e., technician or customer) below, or proceed to the Ethernet mode section to begin adding the camera.

Expand all

Service provider technician - MobileTech app installation ^

1. Log in to the MobileTech app.
2. Find the customer account.
3. Tap +.



Add D...



Comm...



Log in ...



Pause ...



Sensor...

4. Tap **Video**.
5. Using the *Select Device for Guided Installation Tutorial* dropdown menu, select the desired device.
6. Tap **Open Installation Tutorial**.
7. Follow the on-screen instructions.

Customer - Customer app installation wizard ^

1. Log in to the Customer app. You will need the username and password of the account to log in.
2. Tap ☰.
3. Tap **Add Device**. If you do not see the Add Device option, use the Ethernet mode instructions below to complete installation.
4. Tap **Video Camera**.
5. Tap **VC730P**.
6. Follow the on-screen instructions.

Ethernet mode ^

Note: Complete these steps prior to installing the camera in its final location.

1. Feed the Ethernet cable through the cable gland and connect it to the camera's RJ45 port.

2. Connect the other end of the Ethernet cable to the PoE switch.
3. Wait 2 minutes for the camera to boot up and connect to the Internet. The LED will be solid green when this process is complete.
4. Add the device to the account by either selecting the account in the MobileTech app or by using a web browser and entering the following web address: **www.alarm.com/addcamera**. You will need the customer's username and password. For more information about adding a camera to an account, see [Enroll the video device to the customer account](#).
5. Select the camera from the video device list or enter its MAC address to begin adding the camera. The camera's MAC address is located on the bottom of the device or on the packaging.
6. Follow the on-screen instructions to finish adding the camera.

You can now power down the camera and install it in its final location using the included hardware.

Physical installation

Verify there are no obstructions near the camera's installation location. Obstructions close to the camera's lens can lead to poor night vision performance. For information about general installation and maintenance guidelines, see [Video Installation Best Practices](#).

To install the ADC-VC730P in its final location:

Important: If the ADC-VC730P will be using an AC power adapter instead of a PoE switch, the ADC-V730 power adapter is required.

1. Use the included drill template to mark the desired location of the holes for the Ethernet/power cable and mounting screws. Drill a 1/2" hole in the center of the template for the Ethernet/power cable. If mounting to drywall, drill three 9/32" holes and insert the included M5 wall anchors. If mounting to a solid surface (e.g., wood), drill three 1/8" pilot holes.

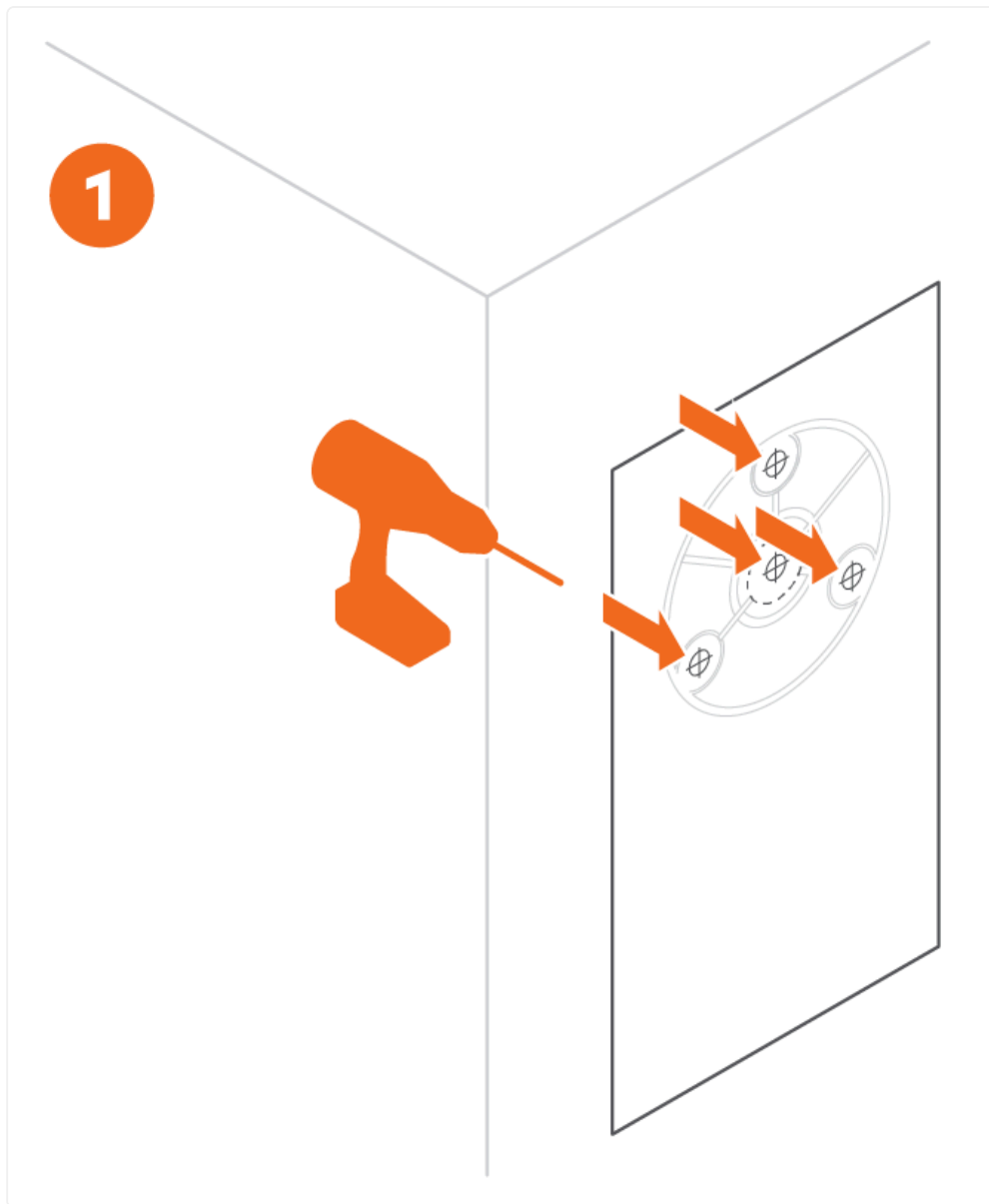

2. Mount the device to a flat surface (e.g., a wall or ceiling) 8 feet or more above the ground.

To mount the ADC-VC730P when routing the Ethernet/power cable through the wall:

^

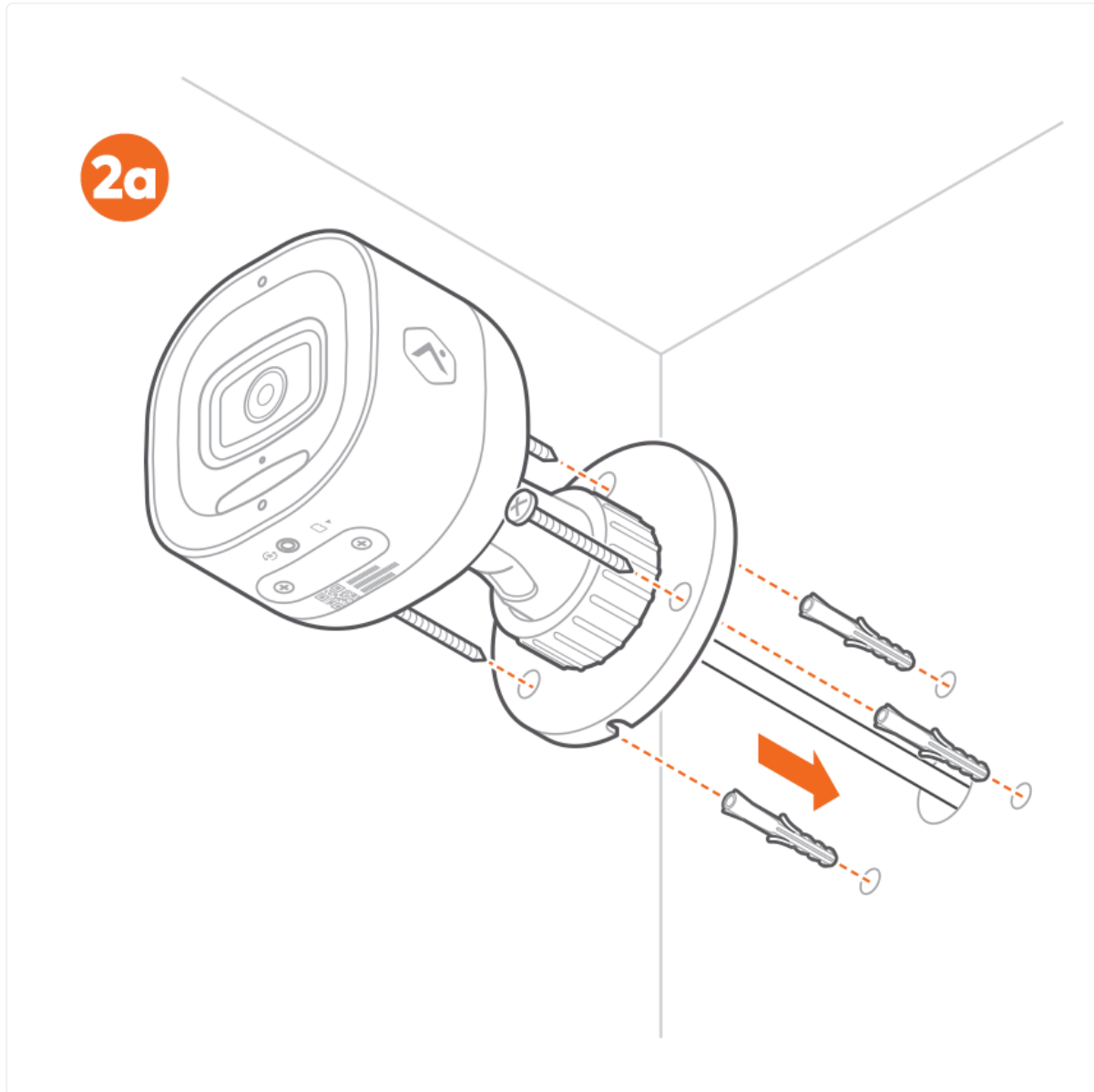

3. Install the rubber plug over the hole for the Ethernet/power cable.
4. Connect the device to its power cabling:
 - If using an Ethernet cable for power, connect the cable to a PoE switch. Insert the Ethernet cable into the center hole from the mounting template.
 - If using an AC power adaptor for power, connect the 12 VDC connector to an unplugged 12 VDC adaptor. Insert the power cable into the center hole from the mounting template.
5. Line up the camera with the three holes created in step 1. Use the included ST4.8 x 32mm self-tapping screws to fasten the camera to the mounting surface (#10 drywall screws or 3/16" Tapcon screws are also acceptable).

To mount the ADC-VC730P when routing the Ethernet/power cable along the wall:

^

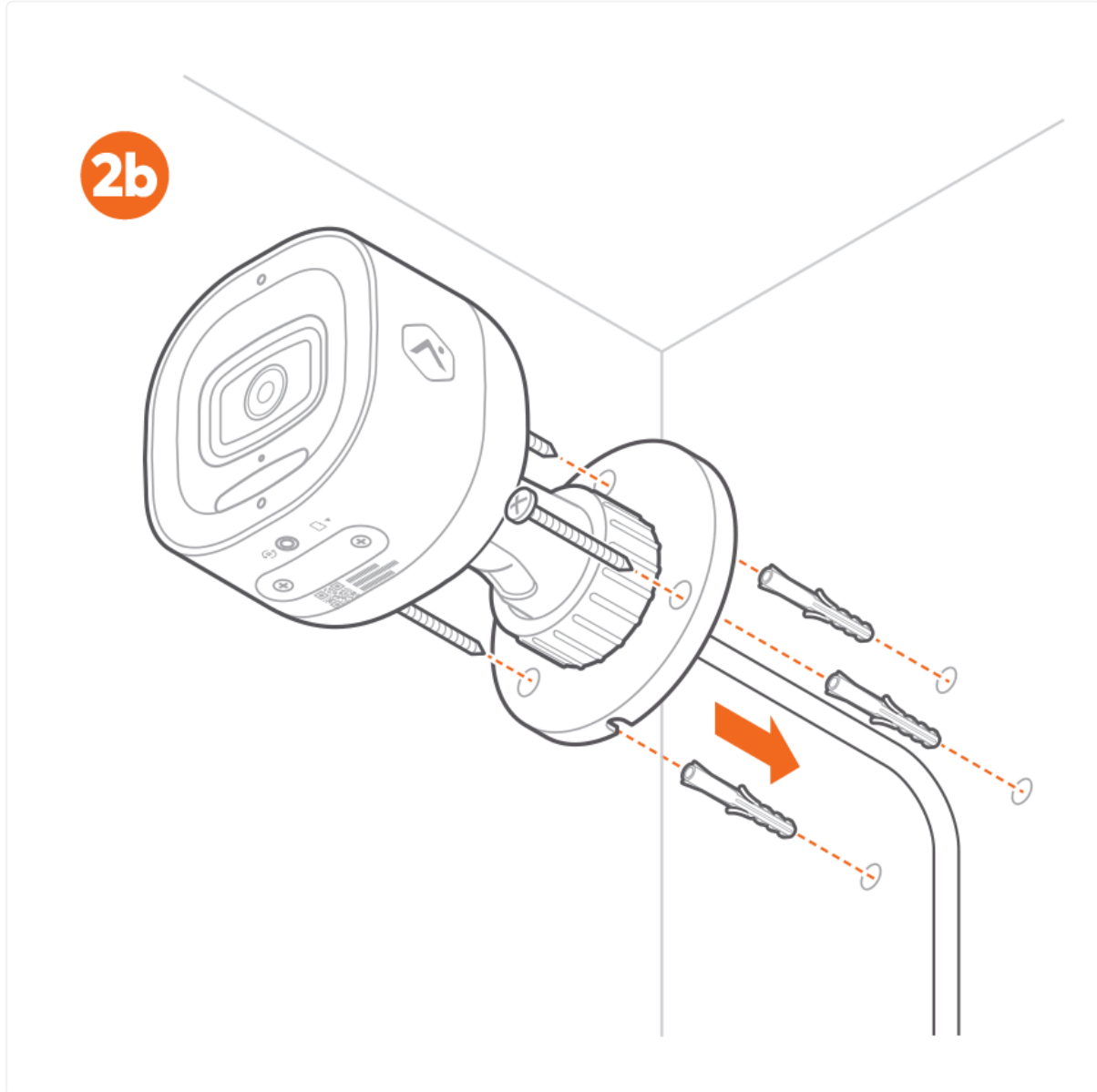

3. Remove the rubber plug from the power cord.
4. Connect the device to its power cabling:
 - If using an Ethernet cable for power, connect the cable to a PoE switch. Insert the Ethernet cable into the center hole from the mounting template.
 - If using an AC power adaptor for power, connect the 12 VDC connector to an unplugged 12 VDC adaptor. Insert the power cable into the center hole from the mounting template.
5. Line up the camera with the three holes created in step 1. Use the included ST4.8 x 32mm self-tapping screws to fasten the camera to the mounting surface (#10 drywall screws or 3/16" Tapcon screws are also acceptable). Route the cable through the cut-out in the mounting plate.

LED reference guide

LED pattern

Description

Off



Power off

Solid green



Connected to Alarm.com

Blinking green



Local network connection

Blinking red



Power on, camera booting

Solid red



No local or internet connection

Blinking yellow



Power cycling (press and hold button for 9-12 seconds)

LED pattern

Description

Blinking red and green



Reverting to factory default settings (press and hold the button for 12-15 seconds)

Blinking green and blue



Firmware updating

Troubleshooting

1. If the camera was previously installed on a different Alarm.com account, it will need to be deleted before it can be installed again.
2. If you have issues connecting the camera to the account, power cycle the camera and try again.

Caution: Prolonged exposure to sunlight in extreme conditions may impact the camera's performance. The optimal installation location is in a shaded area such as under an eave.

Regulatory Statements

Operating Temperature: -40°F – 122°F (-40°C – 50°C)

Ingress Protection: IP66

FCC Statements

FCC Short Part 15 Statement

This device complies with part 15 of the FCC Rules. Operation is subject to the following two conditions: (1) This device may not cause harmful interference, and (2) this device must accept any interference received, including interference that may cause undesired operation.

FCC Long Part 15 Statement

This equipment has been tested and found to comply with the limits for a Class B digital device, pursuant to part 15 of the FCC Rules. These limits are designed to provide reasonable protection against harmful interference in a residential installation. This equipment generates, uses and can radiate radio frequency energy and, if not installed and used in accordance with the instructions, may cause harmful interference to radio communications. However, there is no

guarantee that interference will not occur in a particular installation.

If this equipment does cause harmful interference to radio or television reception, which can be determined by turning the equipment off and on, the user is encouraged to try to correct the interference by one or more of the following measures:

- Reorient or relocate the receiving antenna.
- Increase the separation between the equipment and receiver.
- Connect the equipment into an outlet on a circuit different from that to which the receiver is connected.
- Consult the dealer or an experienced radio/TV technician for help.
- Changes or modifications not expressly approved by the party responsible for compliance could void the user's authority to operate the equipment.

RF Exposure

This equipment complies with FCC and ISED radiation exposure limits set forth for an uncontrolled environment. This equipment should be installed and operated with a minimum distance of 20cm between the equipment and your body. This device and its antenna(s) must not be co-located or operating in conjunction with any other antenna or transmitter. Please contact intsupport@alarm.com for more information on Canadian RF exposure compliance.

FCC ID

FCC ID: YL6-143V730P

ISED Statements

Condition

This device contains license-exempt transmitter(s)/receiver(s) that comply with Innovation, Science and Economic Development Canada's licence-exempt RSS(s). Operation is subject to the following two conditions:

1. This device may not cause interference.
2. This device must accept any interference, including interference that may cause undesired operation of the device.

Cet appareil contient des émetteurs/récepteurs sans licence qui sont conformes aux RSS sans licence d'Innovation, Sciences et Développement économique Canada. L'exploitation est soumise aux deux conditions suivantes :

1. Cet appareil ne doit pas provoquer d'interférences.
2. Cet appareil doit accepter toute interférence, y compris les interférences susceptibles de provoquer un fonctionnement indésirable de l'appareil.

RF Exposure

Cet appareil est conforme aux limites d'exposition aux radiofréquences établies par la FCC et l'ISED pour un environnement non contrôlé. Cet appareil doit être installé et utilisé à une distance minimale de 20 centimètres entre l'appareil et votre corps. Cet appareil et son ou ses antennes ne doivent pas être situés ou fonctionner en conjonction avec une autre antenne ou un autre émetteur. Veuillez communiquer avec intsupport@alarm.com pour obtenir plus d'information sur la conformité aux exigences canadiennes en matière d'exposition aux radiofréquences.

IC ID

ID: 9111A-143V730P