

APPLICATION:

The ELK-120 v3 features 4 channels that can be configured as 2 channels of siren and 2 channels of voice, or all 4 channels can be used for voice. Either way the voice channels are fully recordable and are stored in non-volatile memory. Total time of recording is 8 minutes. The Siren channels offer a choice of: Classic Yelp Sound, Temporal Coded Horn, or Industrial Horn.

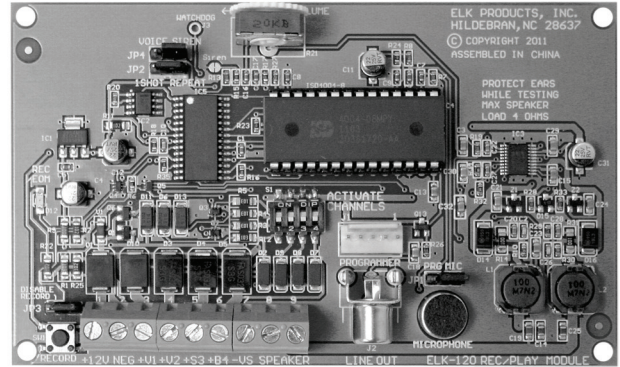

FEATURES:

- Four Channels Configurable as: Two Siren and Two Recordable Voice OR Four Recordable Voice. Maximum record time is 8 minutes divided between the number of voice channels
- Siren Sounds: Classic Yelp Siren, Temporal Coded Horn, and Pulsing Industrial Horn
- Temporal Coded Horn meets ANSI standard for Audible Emergency Evacuation Signaling
- Recordings stored in non-volatile memory
- Voice channels accept momentary triggers
- "One Shot" or Continuous voice playback settings
- Built-in condenser microphone for recording
- Adjustable speaker volume and current draw
- Powerful 24 watt audio amplifier for Speakers
- Line Level Output for Paging Systems and Amplifiers
- PC sound card interface connector
- Lifetime Limited Warranty

SPECIFICATIONS:

- Operating Voltage: 11 to 14 Volts D.C.
- Adjustable current draw: 1/4 to 1.8 Amps
- Low current triggers: 9 to 14 Volts DC @ 30 mA
- Maximum sound level: 122 dB @ 1 meter
- Maximum speaker loading: 4 Ohms
- Pulsing input: 1/2 to 1.5 Sec Pulse, 50% duty cycle
- Size: 3" x 5" x 1.25" (76 x 127 x 32 mm)

Features or Specifications subject to change without notice.

PO Box 100 • Hildebran, NC 28637 USA • 828-397-4200 Voice • 828-397-4415 Fax
<http://www.elkproducts.com> • email: info@elkproducts.com

OPERATION

The 4 channels of the ELK-120 must be configured by Jumper JP4, located in the top left corner of the board. With JP4 in the Siren position the unit will be configured as 2 recordable voice channels and 2 fixed siren sounds. With JP4 in the Voice position, the unit will be configured as 4 recordable voice channels. Voice messages are stored in non-volatile memory and may be re-recorded as needed. Simply configure Jumper JP4 according to your choice of operation and connect according to one of the installation diagrams and the following instructions.

SIREN with VOICE mode

(Jumper JP4 in the SIREN position)

In this mode the 4 channels are split into 2 siren and 2 voice. The siren channels are +S3 (Yelp) and +B4 (Temporal Coded Horn). The voice channels are +V1 and +V2 and have 4 recordable minutes each or 8 minutes combined.

Positive (+) Voltage Activation Terminals

Each channel may be activated by applying 12 Volts DC between the NEG terminal and the positive (+) input. Both a siren and voice channel may be activated at the same time to achieve mixed siren and voice output.

+V1 = Recordable Voice Channel 1 input.

+V2 = Recordable Voice Channel 2 input.

+S3 = Yelp Siren input.

+B4 = Temporal Coded Horn input.

Pulsing Voltage Activation

Terminals +S3 and +V1 can automatically detect a pulsed versus a steady activation and play the alternate channel. For example: if channel +S3 (Yelp) is pulsed then channel +B4 (Horn) will be played. If channel +V1 (Voice 1) is pulsed then channel +V2 (Voice 2) will be played.

Negative (-) Activation Terminal

There is a single terminal marked -VS for controls (eg: DSC) that switch the negative of the alarm output. This terminal automatically plays the appropriate siren and voice combination based upon the input being a steady or a pulse. If the input is a steady negative, the Yelp Siren and Recordable Voice 1 will play. If the input is a pulsed negative, the Horn and Recordable Voice 2 will play. Refer to the wiring diagram.

Mixing Siren Sounds and Voice Messages

To combine a siren sound with a voice message apply +12 Volts DC to both a Siren input and a Voice input at the same time. EG: To obtain a Yelp siren followed by a burglary voice message, +12 Volts DC voltage to channel +S3 and +V1 at the same time. The two channels will alternately play until the trigger is removed. **Exception:** Voice channels can be set to play only once per activation cycle by placing jumper JP2 to the 1SHOT position. The siren sound(s) continue until the activation input is removed.

VOICE Only mode

(Jumper JP4 in VOICE position)

In this mode the 4 channels are all voice recordable and can hold up to 2 minutes of messages each. Two or more channels can be combined into longer messages up to the combined maximum of 8 minutes.

Positive (+) Voltage Activation

To activate a channel simply apply 12 Volts DC between the NEG terminal and the positive (+) channel input. Multiple channels can be combined (activated at the same time) to achieve mixed playback of voice sounds.

+V1 = Recordable Voice Channel 1 input.

+V2 = Recordable Voice Channel 2 input.

+S3 = Recordable Voice Channel 3 input.

+B4 = Recordable Voice Channel 4 input.

NOTE: Pulsing Voltage Activation is not available in Voice Only Mode.

Instructions Common To Both Modes

Volume and Current Adjust

Turning the **Volume** knob clockwise will increase the output volume. The louder the volume, the higher the current draw. The volume and current draw may be adjusted to match the current capability of the power source.

Connecting A Constant Power Source

(To Allow Activation By Low Current Devices)

By connecting the +12V and NEG terminals to a constant power source the current draw of the channel inputs can be reduced to approximately 30 milliamps since all the operating power will then be drawn from the constant power source. A constant power source also allows a voice channel to be activated by a momentary voltage and then finish playing until the end.

Options for Playback of the Voice Channels

The switches marked "Activate Channels" are provided for programming and for user convenience where manual activation of the channel(s) may be desired. A constant power source must be connected to +12V and NEG terminals in order to use these switches.

The 1SHOT position of Jumper JP2 restricts playback of a voice channel to only once per activation cycle. The channel activation must be removed and then re-applied before the message will be allowed to play again. NOTE: 1SHOT does not work with a pulsing activation.

The REPEAT position of Jumper JP2 permits the voice channel to play repeatedly for as long as the channel input is activated.

Recording Voice Messages

Messages may be recorded from the on-board microphone, or from a PC with a sound card and an ELK-129 interface.

To record from the onboard microphone place Jumper JP1 in the MIC position, JP2 in the REPEAT position, and JP3 in the RECORD position. Activate the desired channel either by using the on-board DIP switches (requires power to be applied to +12V and NEG terminals) or by applying +12 Volts DC to the desired input (+V1, +V2, +S3, or +B4). The current message (if any) will start to play. While it is playing, press and hold the record switch SW1 and speak clearly into the on-board microphone. Note that the REC/EOM LED should light before you begin speaking. To minimize any noise, gently release SW1 after speaking. The new message will immediately be played. To stop the playback turn off the channel switch or remove the trigger voltage. To re-record the message, or to record another channel, repeat the above procedure.

To record with the ELK-129 sound card interface place Jumper JP1 in the PRG position, and JP2 in the REPEAT position. Plug the ELK-129 five pin ribbon cable into Programmer Connector J1. Power the ELK-129 and move the SW1 slide switch to CH1 (this will provide power to the ELK-120). Select the channel to record with the on-board DIP switch. Follow the instructions for the ELK-129, Play a "scripted" WAV.

INSTALLATION & HOOKUP EXAMPLES

Note: Dashed Lines Indicate Optional Connections.

Hookup to a Single (one) Alarm Output with a steady / pulse option.

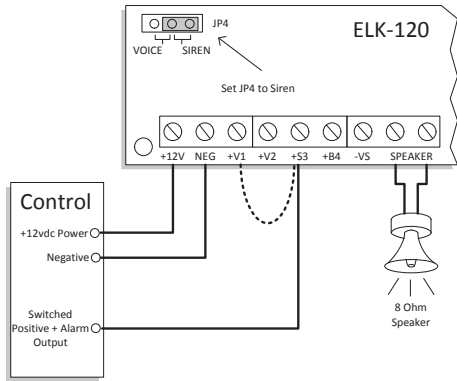

Set JP4 to Siren. A Steady +12 Volts DC applied to +S3 activates the Siren sound. A 1/2 to 1.5 second Pulse to +S3 activates the Horn sound. Adding a wire jumper between +S3 and +V1 will combine the Siren sound with Voice 1 Channel, or Pulsing +S3 combines the Horn sound with Voice 2 Channel.

Hookup to a Switched Negative Single (one) Alarm Output with a steady / pulse option.

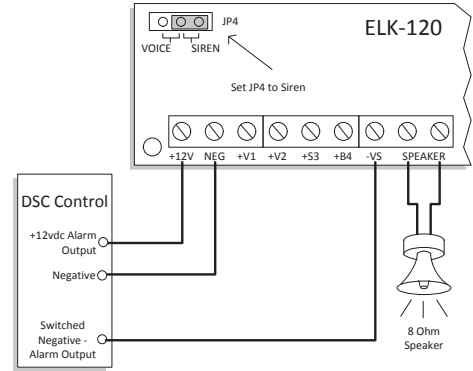

Set JP4 to Siren. This method is great for Controls that switch their negative alarm output (eg: DSC). A Steady Negative to terminal -VS plays the Siren sound combined with Voice 1 Channel. A 1/2 to 1.5 Second Pulse to terminal -VS plays the Horn sound combined with Voice 2 Channel.

Momentary or Low Current Trigger Method: One or two positive alarm outputs capable of 30 mA.

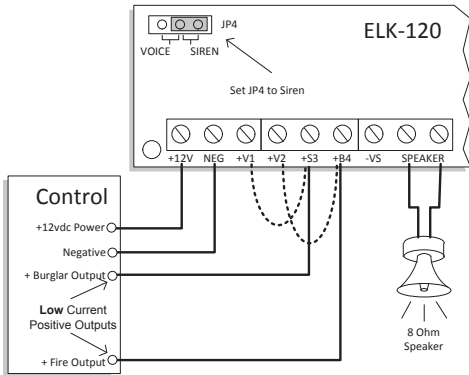

Set JP4 to Siren. The operating current is drawn from the constant +12 Volts DC power source. The +V1 and +B3 channel trigger terminals draw only 30 mA each from the control alarm outputs.

Industrial Horn Siren Sound

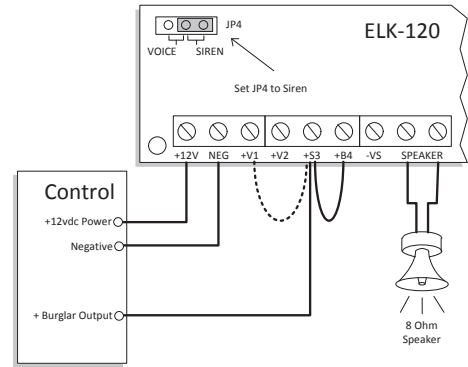

Set JP4 to Siren. Industrial horn will play if +S3 and +B4 are connected and activated together. Adding a wire jumper between +S3 and +V1 will combine the Horn with Voice 1 Channel.

Standard Method: Control panel with two alarm outputs capable of 2 Amps max. each.

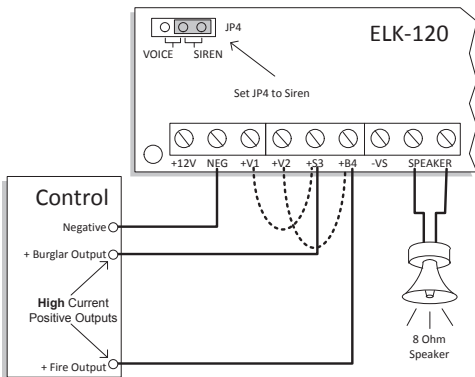

Set JP4 to Siren. All current must be supplied from the Burg and Fire Outputs on the Control. Average current draw with 8 Ohm speaker load is 1.2 Amps, or 1.8 Amps with 4 Ohm load.

Voice Mode

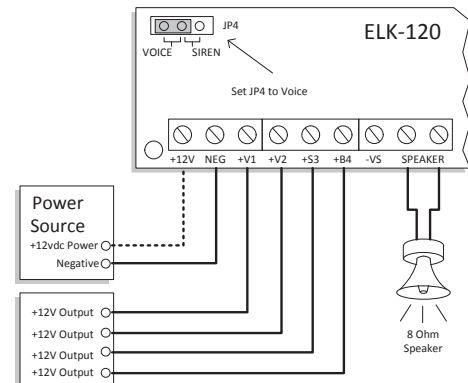

Set JP4 to Voice. A recordable voice channel may be played by connecting 12 Volts DC between the NEG terminal and the positive (+) channel input. For low current triggering of a channel, or to have messages play through to the end when activated by a momentary trigger, connect terminal +12V to a constant +12 Volt DC source.

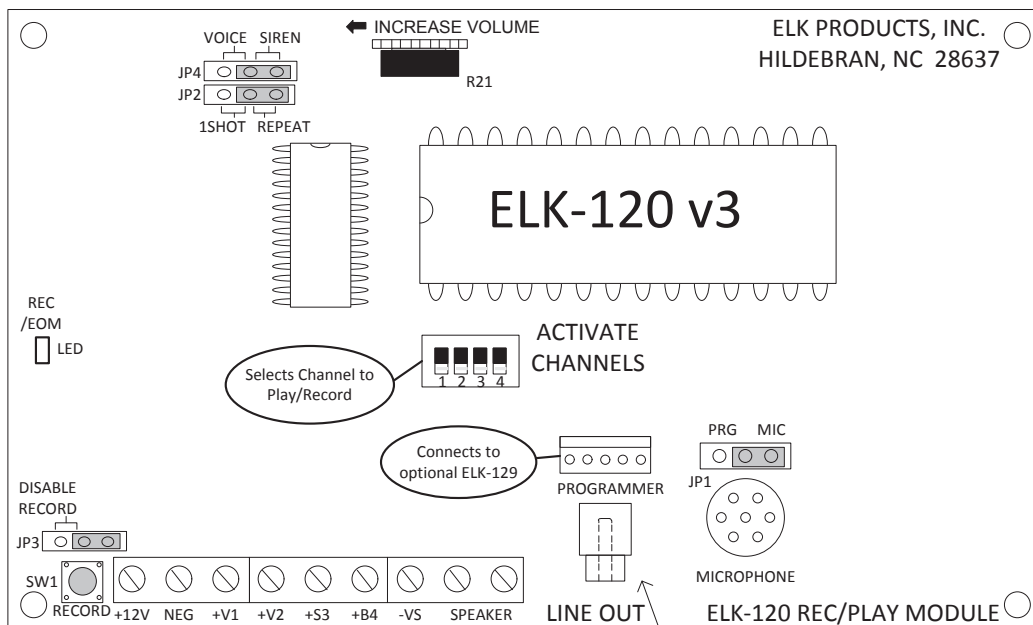

Figure 1

Line Level Output (RCA Jack)
for connecting to the input of a
paging system or audio amplifier

Summary of Connection Terminals & Switches

[+12V] If using a constant 12 Volt DC power source, connect the positive side here. Nominal operating range of the ELK-120 is 11 to 14 Volts DC. This input is only required if: A. The -VS negative trigger terminal is used. B. Momentary activation of the channels is desired. C. The activating source equipment is current limited to 30 mA or less.

[NEG] Connect to the negative side of the 12 Volt DC power source. Also connect the negative from external trigger inputs here if they are from another power source.

[+V1] Positive trigger input for Voice channel 1

[+V2] Positive trigger input for Voice channel 2

[+S3] Positive trigger input for Yelp Siren or Voice channel 3

[+B4] Positive trigger input for Temporal Coded Horn or Voice channel 4

[-VS] Negative trigger input for controls with a switched negative output

[SPEAKER] Connect to 8 ohm speaker. (Max 4 Ohm load)

[Volume Control (R21)] Adjusts volume of the speaker output.

[Activate Channels] Selects channel to be recorded. Power must be applied to the +12V and NEG terminals to use this switch.

[Record Switch (SW1)] To record a message, set JP1 to MIC, activate desired channel, press SW1, then speak your message into the on-board microphone.

[Programmer (J1)] The optional ELK-129 Computer Sound Card Interface module connects to this 5 pin connector to allow computer WAV sound files to be downloaded into the ELK-120.

[Line Out (J2)] This RCA type connector provides line level sound output for connection to Public Address amplifiers

NOTE: Channels may be combined to mix the output

Jumper Settings

JP1	MIC	Record using the on-board microphone
	PRG	Record using the optional ELK-129 sound interface
JP2	REPEAT	Continuously replays a channel while triggered
	1SHOT	Plays a triggered channel only once. NOTE: 1Shot is not available for pulsing input mode.
JP3	RECORD	Enables the on-board record switch SW1
	DISABLE	Disables record switch, prevents accidental recordings
JP4	SIREN	Sets +S3 & +B4 to be Yelp Siren & Horn channels
	VOICE	Sets +S3 & +B4 to be Recordable Voice channels 3 & 4

Siren with Voice Mode (JP4 = Siren)(for Alarm Applications)

+V1 = 0 to 8 Minute Recordable Message, see note

+V2 = 0 to 4 Minute Recordable Message

+S3 = Yelp Siren

+B4 = Temporal Coded Horn

+S3 and **+B4** together = Industrial Horn

-VS = Alternately plays Yelp Siren and Voice 1 message

Pulsing the +V1 input will play Voice 2 message

Pulsing the +S3 input will play the Temporal Coded Horn

Pulsing the -VS input will alternately play the Horn and Voice 2 message

Note: If Voice 1 (+V1) message recording exceeds 4 minutes, it will overwrite Voice 2 (+V2) message space, thus +V2 becomes unusable

Voice Only Mode (JP4 = Voice)

+V1 = 0 to 8 Minute Recordable Voice 1 Message, see note

+V2 = 0 to 6 Minute Recordable Voice 2 Message

+S3 = 0 to 4 Minute Recordable Voice 3 Message

+B4 = 0 to 2 Minute Recordable Voice 4 Message

-VS = Alternately plays Voice 1 and Voice 3 messages

Pulsing Mode is not available in Voice Mode

Note: If message recordings exceed 2 minutes they will overwrite the next adjacent message, thus adjacent message becomes unusable