

ELK Sealed Lead Acid Battery

Two-Year Warranty

ELK Sealed Lead Acid Batteries are excellent for the following applications with regard to size, amp hour rating, and proper terminal connections: battery backup (for access control systems, fire alarm systems, and security alarm systems), electrically motorized vehicles, emergency lights, lighted exit signs, and uninterruptible power supplies.

ELK-1280 12V, 8 Ah

SPECIFICATIONS:	
Nominal Voltage	12 Volts
Rated Capacity	8 Ah (20 hour rate)
Length	5.94" (151 mm)
Width	2.56" (65 mm)
Height	3.98" (101 mm)
Weight (Approximate)	5.6 lbs (2.5 kg)
Terminals	F1 Faston Tab (.187")



ELECTRICAL SPECIFICATIONS:		
Capacity 77°F(25°C)	20 hour rate (0.375A)	8Ah
	10 hour rate (0.71A)	7.1Ah
	5 hour rate (1.27A)	6.37Ah
	1 hour rate (4.5A)	4.5Ah
Capacity affected by Temperature (20 hour rate)	104°F (40°C)	102%
	77°F (25°C)	100%
	32°F (0°C)	85%
	5°F (-15°C)	65%
Charge Constant Voltage	Cycle: Initial Charging Current less than 2.25A	
	Standby: Voltage 13.5V - 13.8V at 77°F(25°C)	

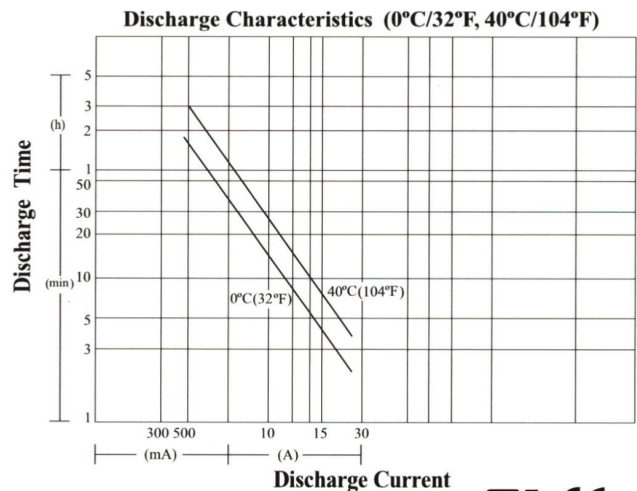
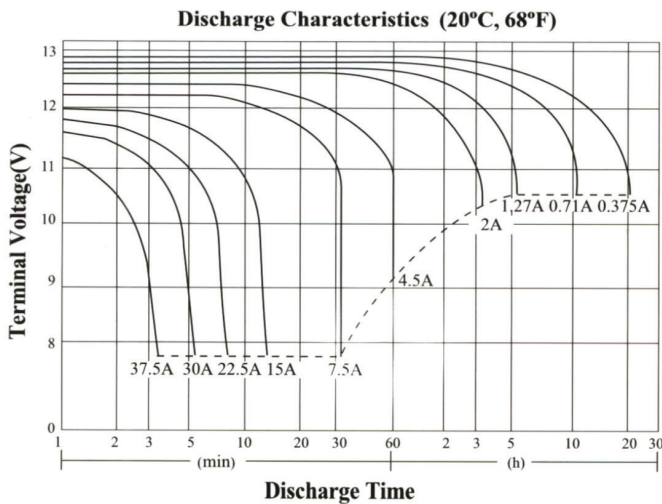
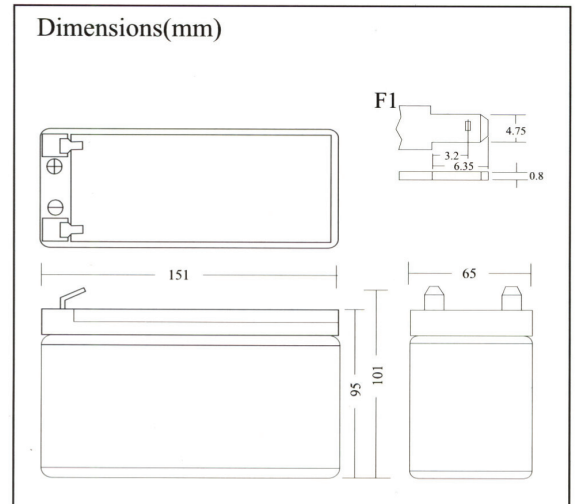

For more information, including details on recycling ELK batteries and MSDS for this product, please visit www.elkproducts.com or call us at (828) 397-4200.

