

Power Supply & Battery Charger

ELK-P624

The ELK-P624 is a general purpose regulated power supply and battery charger. It is ideal for alarm, access control, and CCTV applications requiring up to 1 Amp continuous current. Automatic resetting "fuseless" overload protection means never having to return to a job site to replace a blown fuse.

On-board diagnostic LEDs indicate the presence of the A.C. charging and D.C. output voltages. The output voltage can be set with a mini-jumper.

Features

- Selectable 6, 12, or 24 Volts D.C. Operation.
- Automatic Resetting "fuseless" Overload Protection (PTC).
- Visual AC and DC Power Indicators.
- Built-In Battery Charge Circuit.
- Small, Compact Size.
- Includes Double Sided Mounting Tape.
- A.C. and D.C. Surge Suppression.
- Lifetime Limited Warranty.

Specifications

6VDC Setting:

- Current Rating: 1.2A.
- with 12V, 40VA Transformer.

12VDC Setting:

- Current Rating: 1.0A.
- with 16.5V, 40VA Transformer.

24VDC Setting:

- Current Rating: 800mA.
- with 24V, 40VA Transformer.

- Standby Battery Capacity: 1.2 to 10 AH.
- Size: 3" X 3" (76.2mm X 76.2mm).

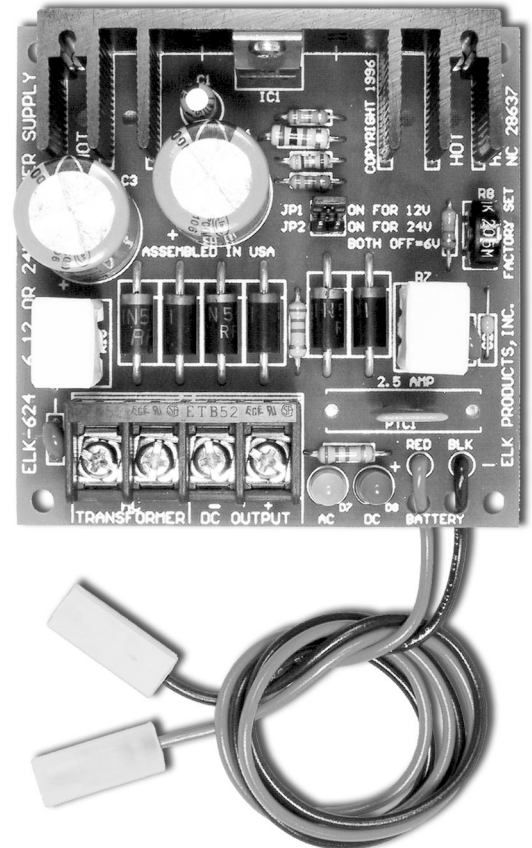

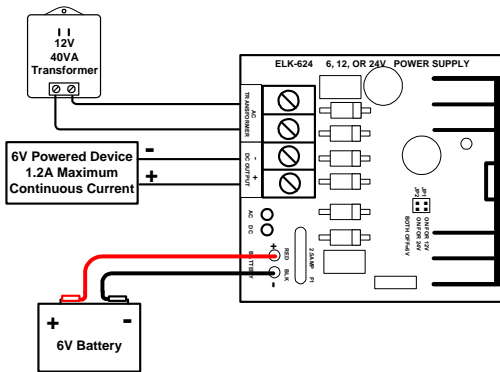
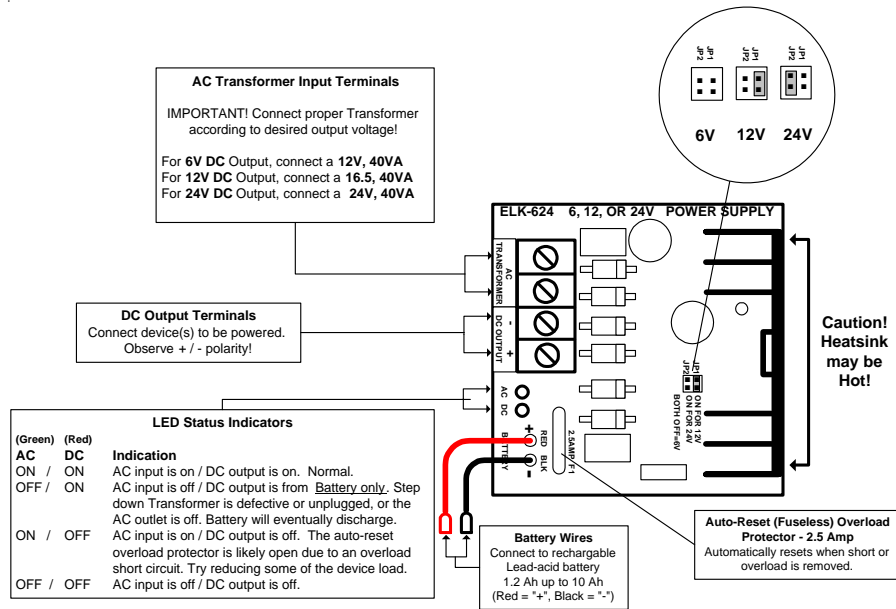

6 VOLT MODE

For 6 volt output, remove the small black mini-jumper from the header pins marked JP1 and JP2. (See Figure 1 above) Then connect a 12Vac, 40VA transformer to the AC TRANSFORMER terminals and connect a 6V battery to the red (+) and black (-) battery wires. The mini-jumper may be discarded or stored for later use by placing one side onto a single header pin.

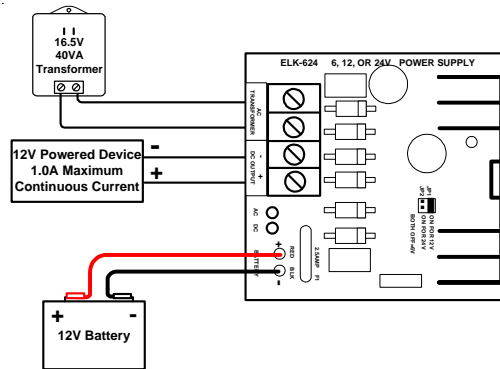

12 VOLT MODE

For 12 volt output, place the small black mini-jumper on the header pins marked JP1. (See Figure 1 above) Make certain that header pin JP2 is vacant. Connect a 16.5 Vac, 40VA transformer to the AC TRANSFORMER terminals and connect a 12V battery to the red (+) and black (-) battery wires.

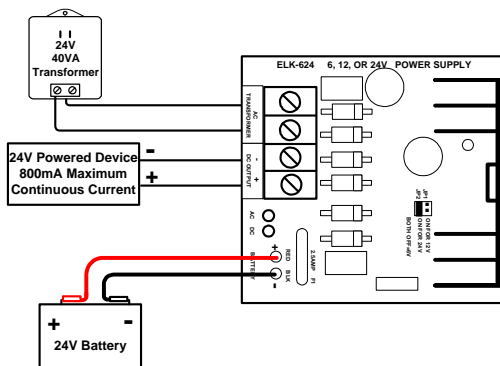

24 VOLT MODE

For 24 volt output, place the small black mini-jumper on the header pins marked JP2. (See Figure 1 above) Connect a 24 Vac, 40VA transformer to the AC TRANSFORMER terminals and connect a 24V battery to the red (+) and black (-) battery wires.