

# SURFACE SPEAKER/MICROPHONE MODULE

Cat. No. 28A00-1

## Installation Instructions

**LEVITON**®

DI-022-OA281-00A  
(28100-1)

### INSTALLATION

ENGLISH

#### WARNINGS AND CAUTIONS

- Read and understand all instructions. Follow all warnings and instructions marked on the product.
- Do not use this product near water - e.g., near a tub, wash basin, kitchen sink or laundry tub, in a wet basement, or near a swimming pool.
- Never push objects of any kind into this product through openings, as they may touch dangerous voltages.
- SAVE THESE INSTRUCTIONS.

#### WARNINGS AND CAUTIONS

- Never install communications wiring or components during a lightning storm.
- Never install communications components in wet locations unless the components are designed specifically for use in wet locations.
- Never touch uninsulated wires or terminals unless the wiring has been disconnected at the network interface.
- Use caution when installing or modifying communications wiring or components.

#### SPECIFICATIONS

Speaker Type:	Polypropylene Weather Resistant
Voice Coil:	8 Ohms
Power Rating:	15 Watts
Microphone:	Electret Condenser, Omni-Directional
Housing and Enclosure Material:	UL-94 Flame Retardant Plastic
Color:	Decorator White
Dimensions:	5 3/16" H x 5 3/16" W x 2 5/8 D
Hardware:	14 Mounting Screws and 8 Wall Anchors
Enclosure Knockouts	Knockouts for wire and plastic duct

#### DESCRIPTION

The Model 28A00-1 is a speaker and microphone assembly mounted in a surface mount enclosure that allows two-way communication with a central station after an alarm, paging and listening from an on-premises or remote phone, annunciation of alarm and zone by voice, and voice messaging \*. It may be used outdoors in weather protected areas such as overhangs, eaves, etc.

\*Voice messaging not available on all systems

#### INSTALLATION

1. Mount the backbox to a 4" electrical box, a single gang electrical box, or directly to surface of a wall using provided hardware.
2. Using a screwdriver with a small blade, remove the screw that holds the grille to the speaker/microphone assembly.
3. Place the screwdriver in the slots (top and bottom on the rear of the speaker/microphone assembly) to remove the speaker grille.
4. Connect the wire from the Speaker (Output) on the Two-Way Voice Module to the (+) terminal on the speaker.
5. Connect the wire from the Speaker (Common) on the Two-Way Voice Module to the (-) terminal on the speaker.
6. Route the microphone wires from the Two-Way Voice Module through the hole in the speaker/microphone assembly marked "A" in Figure 2.
7. Connect the wire from the Microphone (+) on the Two-Way Voice Module to the Red microphone wire.
8. Connect the wire from the Microphone (Common) on the Two-Way Voice Module to the Black microphone wire.

FIGURE 1 – Speaker/Microphone Connections

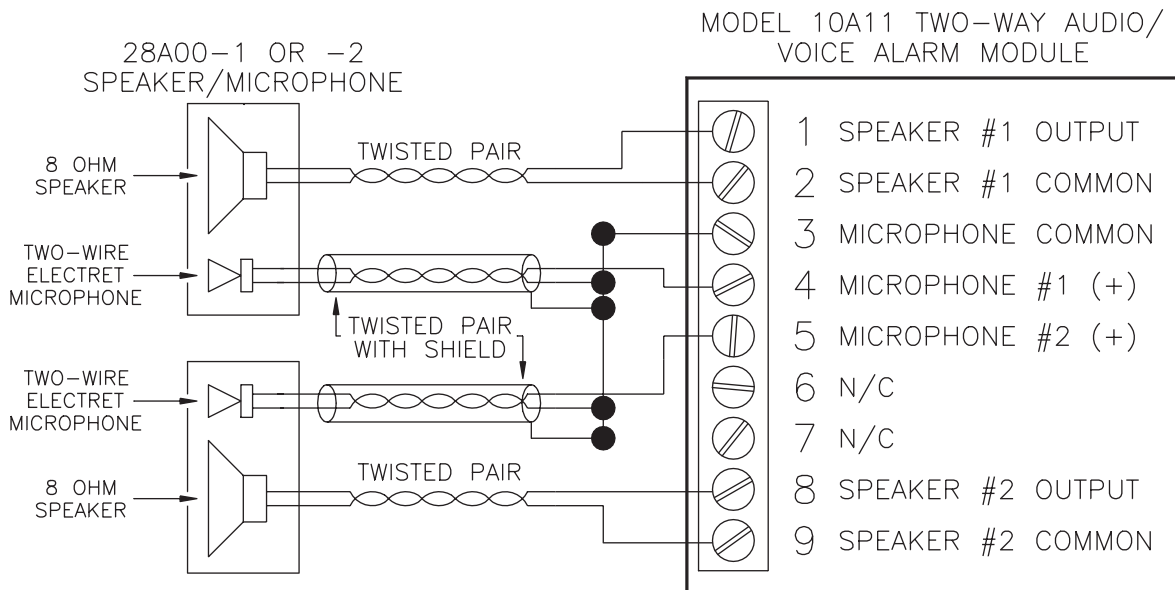

Microphones should be connected with 24 AWG or larger, shielded twisted pair wire. Wire length should not exceed 100 feet. Connect the cable shields and negative wires together at the Model 10A11 terminal block only. Do not connect the shield on the microphone end. Additional microphones can be connected to each input in parallel.

Speakers should be connected with 18 AWG or larger, twisted pair wire. For wire runs that exceed 50 feet, use 16 AWG wire or larger. Wire length should not exceed 100 feet. Additional speakers can be connected to each output in series.

WEB VERSION

9. Secure the speaker/microphone assembly to the backbox using the provided screws (Figure 2).

FIGURE 2 – Installing the Speaker/Microphone Assembly

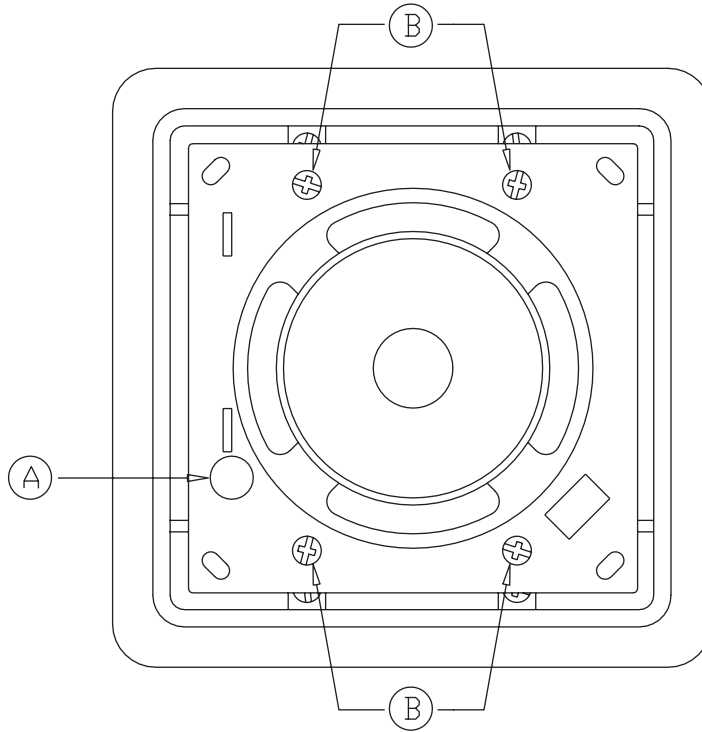

10. Snap the grill back onto the speaker/microphone assembly and replace screw (from step 2) to secure.

#### FOR CANADA ONLY

For warranty information and/or product returns, residents of Canada should contact Leviton in writing at **Leviton Manufacturing of Canada Ltd to the attention of the Quality Assurance Department, 165 Hymus Blvd, Pointe-Claire (Quebec), Canada H9R 1E9** or by telephone at **1 800 405-5320**.

#### LEVITON LIMITED WARRANTY

Leviton warrants to the original consumer purchaser and not for the benefit of anyone else that products manufactured by Leviton under the Leviton brand name ("Product") will be free from defects in material and workmanship for the time periods indicated below, whichever is shorter: • **OmniPro II and Lumina Pro:** three (3) years from installation or 42 months from manufacture date. • **OmniLT, Omni Ite, and Lumina:** two (2) years from installation or 30 months from manufacture date. • **Thermostats, Accessories:** two (2) years from installation or 30 months from manufacture date. • **Batteries:** Rechargeable batteries in products are warranted for ninety (90) days from date of purchase. **Note:** Primary (non-rechargeable) batteries shipped in products are not warranted. **Products with Windows® Operating Systems:** During the warranty period, Leviton will restore corrupted operating systems to factory default at no charge, provided that the product has been used as originally intended. Installation of non-Leviton software or modification of the operating system voids this warranty. Leviton's obligation under this Limited Warranty is limited to the repair or replacement, at Leviton's option, of Product that fails due to defect in material or workmanship. Leviton reserves the right to replace product under this Limited Warranty with new or remanufactured product. **Leviton will not be responsible for labor costs of removal or reinstallation of Product.** The repaired or replaced product is then warranted under the terms of this Limited Warranty for the remainder of the Limited Warranty time period or ninety (90) days, whichever is longer. This Limited Warranty does not cover PC-based software products. **Leviton is not responsible for conditions or applications beyond Leviton's control. Leviton is not responsible for issues related to improper installation, including failure to follow written installation and operation instructions, normal wear and tear, catastrophe, fault or negligence of the user or other problems external to the Product.** To view complete warranty and instructions for returning product, please visit us at [www.leviton.com](http://www.leviton.com).

#### COPYRIGHT AND TRADEMARK INFORMATION

This document and all its contents herein are subject to and protected by international copyright and other intellectual property rights and are the property of Leviton Manufacturing Co., Inc, its subsidiaries, affiliates and/or licensors. © 2013 Leviton Manufacturing Co., Inc. All rights reserved. Use herein of third party trademarks, service marks, trade names, brand names and/or product names are for informational purposes only, are/may be the trademarks of their respective owners; such use is not meant to imply affiliation, sponsorship, or endorsement. No part of this document may be reproduced, transmitted or transcribed without the express written permission of Leviton Manufacturing Co., Inc.