



NAPCO®  
333 Bayview Avenue  
Amityville, New York 11701

For Sales and Repairs, (800) 645-9445  
For Technical Service, (800) 645-9440 or visit us at  
<http://tech.napcosecurity.com/>

(Note: Technical Service is for security professionals only)  
Publicly traded on NASDAQ Symbol: NSSC

# GEMC-F8ZCPIM

## Conventional 8 Fire Zone Expander Plug in Module INSTALLATION INSTRUCTIONS

© NAPCO 2014

WI1651B 12/14

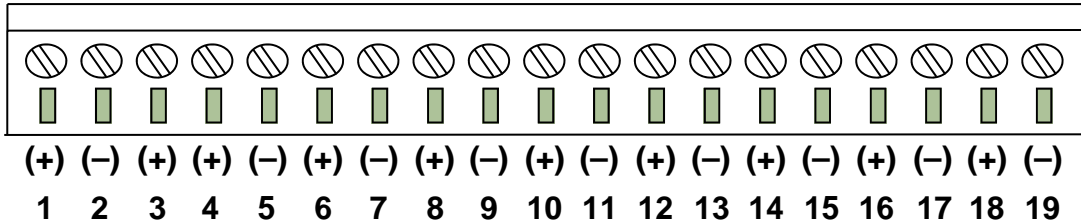

All Circuits  
Class B, Style B

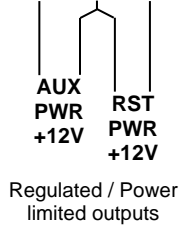

- CO Detector
- Pull Station
- Heat Detector
- Smoke Detector

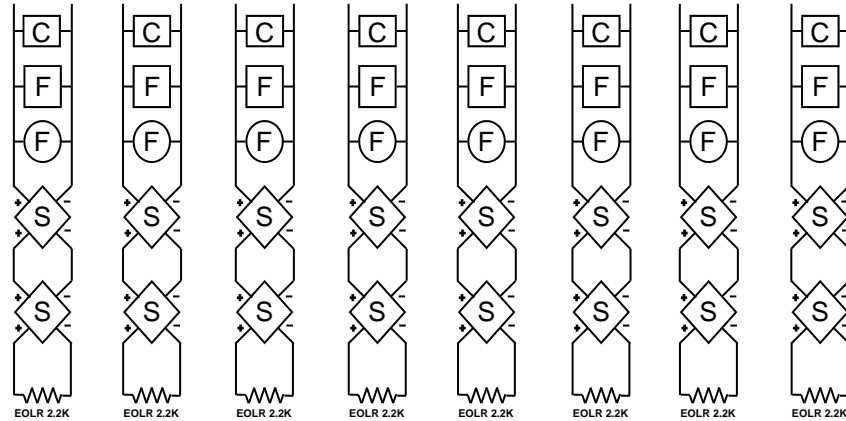

Maximum one (1) wire per terminal

Wire Range  
12-24 AWG

Isolated integral ground-fault detection circuit (detects 1.25KΩ to ground or less)

Note: Inputs 1-8 are supervised

**Caution:** Do not mix pull stations and/or heat detectors on zones with smoke detectors using internal sounders. Do not mix CO detectors with any other devices on the same zone.

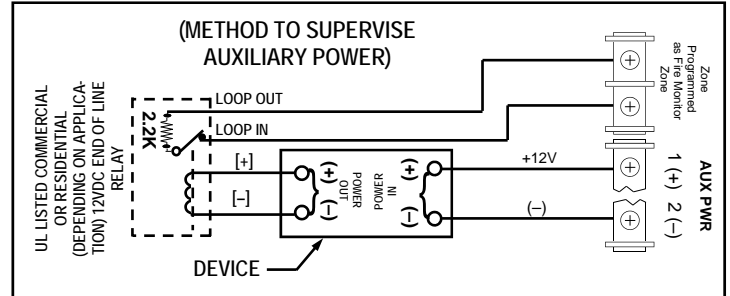
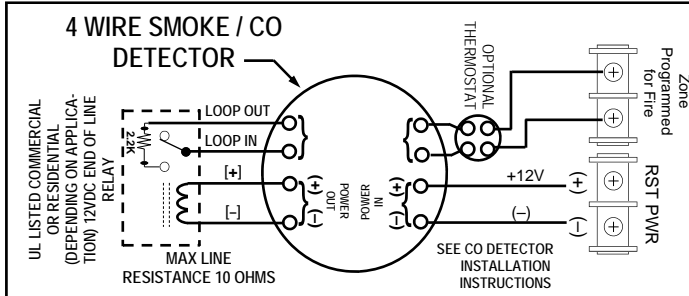

### INSTALLING THE GEMC-F8ZCPIM

Before attempting to install the GEMC-F8ZCPIM, *remove the AC power and battery harness from the GEMC-Series motherboard.* Insert GEMC-F8ZCPIM into the polarized J1 and J1A connectors on the motherboard above terminals 11-17, making sure all 9 pins are inserted into the two connectors correctly, and with the GEMC-F8ZCPIM terminals facing front. Wire initiating circuits, then re-power and test the system. **Note: Use only 12V listed devices and only 2 wire smoke detectors listed with this system (see WI1653 for compatible detectors and maximum devices per zone).** **Important:** Only smoke detectors are permitted on zones programmed with Fire Alarm Verification. Never install Pull Stations, Heat Detectors etc. on zones programmed with Fire Alarm Verification.

### ELECTRICAL RATINGS

**Input Power:** 12V Regulated, 120mA standby + total combined standby & alarm current.

**Output Power:**

**AUX PWR:** 12V Regulated, 700mA maximum.

**RST PWR:** 12V Regulated, 700mA maximum.

**Maximum Total Combined Standby and Alarm Current:** 120MA + total combined standby current. Must reduce GEMC-Series motherboard total combined 12V standby power by GEMC-F8ZCPIM total combined standby current.

**Zone Ratings:**

**Voltage:** 12VDC nominal.

**Current:** 2mA maximum detector current per zone loop.

**Alarm:** 42mA maximum alarm current per zone.

**Maximum Loop Resistance:** 10 ohms.

**Note:** Zones not programmed into Area 1 and not wired with an EOLR will not pull any current in standby or in alarm. All initiating circuits are Class B.

**Compatibility Identifier:** GEMC.

# Wiring the FW-2S Smoke Detector to the GEMC-F8ZCPIM

Firewolf model FW-2S smoke detectors can be used with the GEMC-XXXMB C-Series motherboards and a GEMC-F8ZCPIM *Conventional 8 Fire Zone Expander Plug in Module*. The maximum number of FW-2S units that can be used per zone varies if all of the FW-2S units have their integral sounders enabled or disabled.

**Note:** Do not mix and match other detectors or other appliances on the same zone. Do NOT use FW-2S units WITH enabled sounders on the same zone as FW-2S units WITHOUT enabled sounders.

## Wiring the FW-2S WITHOUT Integral Sounder

A maximum of forty (40) FW-2S detectors can be used on each of the GEMC-XXXMB 8 zones, for a total maximum of 320 FW-2S smoke detectors per system. Refer to the wiring diagram on page 1 of these instructions when wiring the FW-2S units.

## Wiring the FW-2S WITH Integral Sounder

A maximum of thirty-two (32) FW-2S detectors can be used on one zone of the GEMC system (the maximum total for all 8 zones is thirty-two (32) FW-2S detectors). Each zone wired in this manner requires one **GEMC-SDW Schottky Diode Wire**.

The **GEMC-SDW Schottky Diode Wire** is a UL Listed sub-assembly to the Gemini C-Series combination control panel, allowing the GEMC-XXXMB series control panels to support FW-2S two-wire smoke detectors when used with the GEMC-F8ZCPIM *Conventional 8 Fire Zone Expander Plug in Module*.

**IMPORTANT:** Before wiring and programming, the J600 shunt (circled in the image on the next page) **MUST** be removed in order to change NAC D from 24V to 12V. Connect the GEMC-SDW as described below. **Note:** The wire nuts shown in the diagram below represent UL Listed wire connectors suitable for the application.

NUMBER OF FW-2S SMOKE DETECTOR UNITS ALLOWED WHEN USED WITH A GEMC-XXXMB AND WIRED TO A GEMC-F8ZCPIM		
	WITH Integral Sounder Wired / Enabled	WITHOUT Integral Sounder Wired / Enabled
Maximum FW-2S units Allowed Per Zone	32	40
Maximum FW-2S units Allowed Per System	32	320

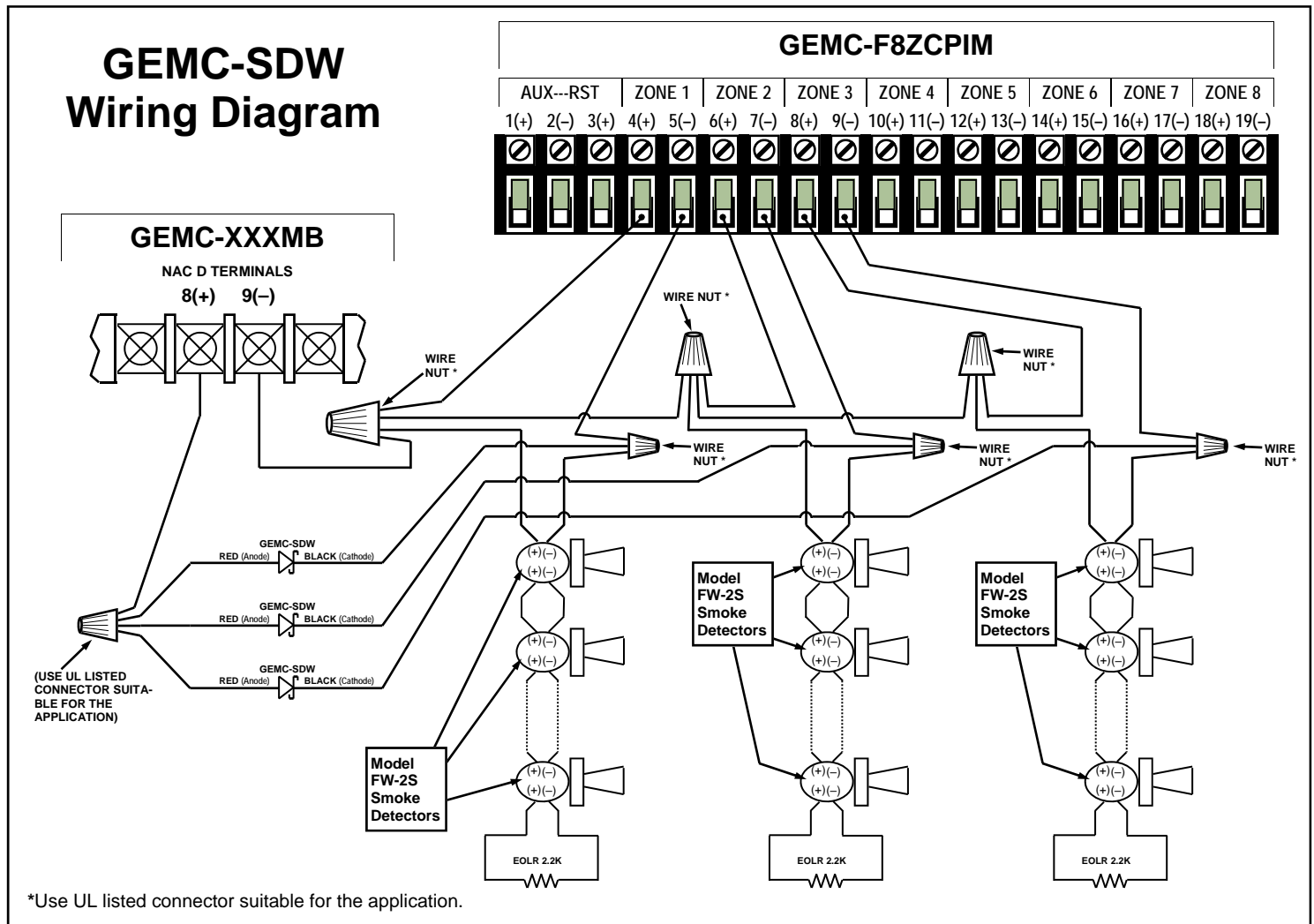

## FW-2S OPERATION

When wired and programmed as directed, any single FW-2S initiating an alarm causes the fire sounders of all FW-2S to activate. In addition, any fire alarm detected by other means on the system will activate the same integral sounders. If the alarm was initiated by another zone in the system, the FW-2S detectors on different zones will sound and will still be able to detect one subsequent alarm per zone.

## INSTALLATION

Wiring model FW-2S to the GEMC-XXXMB Series NAC circuit to activate all sounders on the circuit when any detector on the circuit initiates an alarm:

1. **IMPORTANT!: Remove the J600 shunt (circled in the image below) to change NAC D from 24V to 12V.**
2. Wire as shown in the wiring diagram shown on page 2.
3. Program associated zones 1-8 as Area 1 (Fire).
4. Program NAC D to activate on Fire alarm, program "Silence-able" and an audible temporal pattern of "ANSI 3.41". Optionally activate separate NAC on any fire alarm steady and un-timed for latching strobes.

5. Program "Disable Supervision" for NAC D.
6. Enable GEMC-F8ZCPIM.
7. Available 12V combined alarm current must be reduced by 20mA for each zone used in this fashion. Available 2A/12V NAC D alarm current must be reduced by 60mA for each detector.

## OPERATION EXAMPLE

Four (4) FW-2S's are each wired to zones 1-8, and a second FW-2S on zone 3 detects a fire alarm. The following system operations will occur:

1. The system will announce a fire alarm;
2. All FW-2S integral sounders will activate with a synchronized temporal fire alarm sounder;
3. The FW-2S that initiated the alarm will latch the alarm LED until the system is reset;
4. The FW-2S's on zones 1, 2 and 4 will activate subsequent alarms (will report to the Central Station and will be added to the keypad display); if the FW-2S's detect a fire, they will latch the associated fire LEDs until reset.
5. Unlocking a GEMC-FK1 Fire keypad and pressing **SILENCE** will turn off all sounders, but the initiating detectors with latched LEDs remain latched;
6. Pressing **RESET** unlatches latched LEDs, if detectors are clear of smoke.

# CAUTION

CAUTION

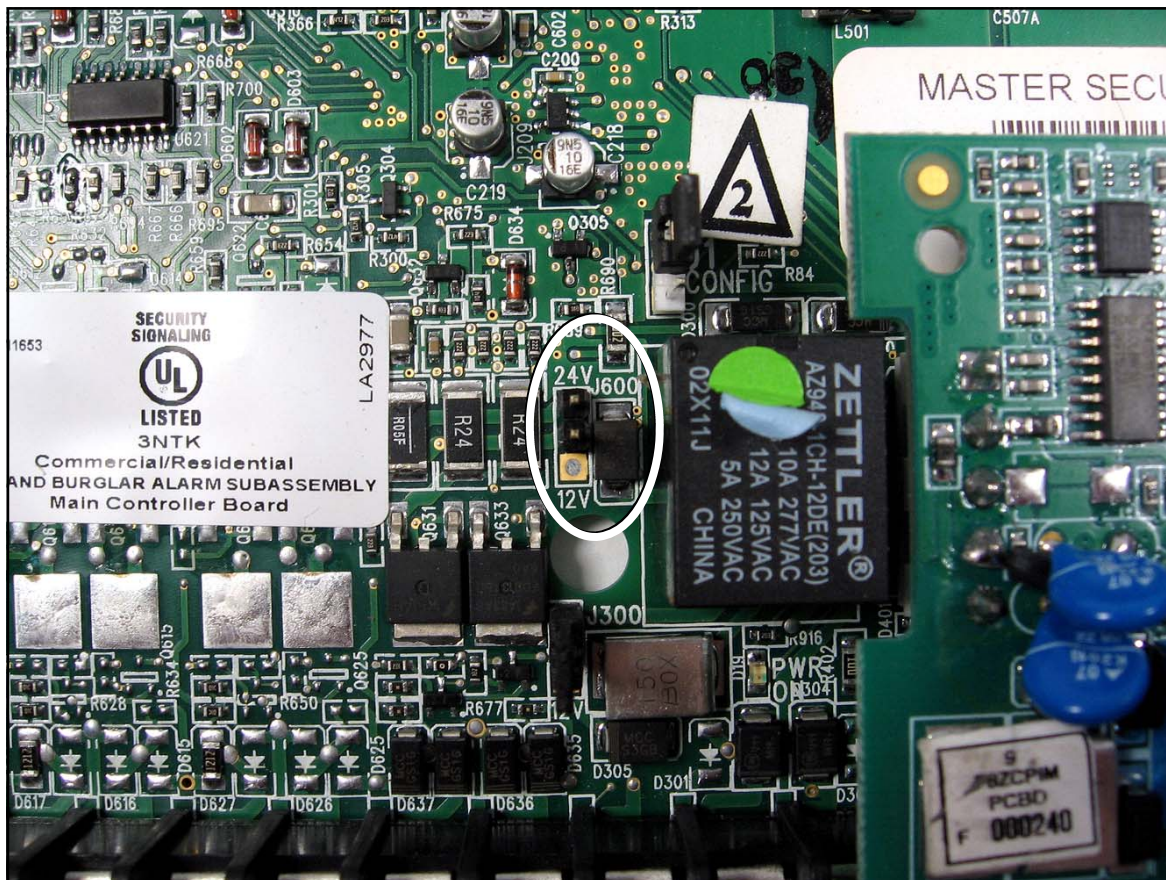

CAUTION

**IMPORTANT: Remove the J600 shunt (circled) to change NAC D from 24V to 12V.**

# NAPCO LIMITED WARRANTY

NAPCO SECURITY SYSTEMS, INC. (NAPCO) warrants its products to be free from manufacturing defects in materials and workmanship for *thirty-six months* following the date of manufacture. NAPCO will, within said period, at its option, repair or replace any product failing to operate correctly without charge to the original purchaser or user.

This warranty shall not apply to any equipment, or any part thereof, which has been repaired by others, improperly installed, improperly used, abused, altered, damaged, subjected to acts of God, or on which any serial numbers have been altered, defaced or removed. Seller will not be responsible for any dismantling or reinstallation charges.

THERE ARE NO WARRANTIES, EXPRESS OR IMPLIED, WHICH EXTEND BEYOND THE DESCRIPTION ON THE FACE HEREOF. THERE IS NO EXPRESS OR IMPLIED WARRANTY OF MERCHANTABILITY OR A WARRANTY OF FITNESS FOR A PARTICULAR PURPOSE. ADDITIONALLY, THIS WARRANTY IS IN LIEU OF ALL OTHER OBLIGATIONS OR LIABILITIES ON THE PART OF NAPCO.

Any action for breach of warranty, including but not limited to any implied warranty of merchantability, must be brought within the six months following the end of the warranty period. IN NO CASE SHALL NAPCO BE LIABLE TO ANYONE FOR ANY CONSEQUENTIAL OR INCIDENTAL DAMAGES FOR BREACH OF THIS OR ANY OTHER WARRANTY, EXPRESS OR IMPLIED, EVEN IF THE LOSS OR DAMAGE IS CAUSED BY THE SELLER'S OWN NEGLIGENCE OR FAULT.

In case of defect, contact the security professional who installed and maintains your security system. In order to exercise the warranty, the product must be returned by the security professional, shipping costs prepaid and insured to NAPCO. After repair or replacement, NAPCO assumes the cost of returning products under warranty. NAPCO shall have no obligation under this warranty, or otherwise, if the product has been repaired by others, improperly installed, improperly used, abused, altered, damaged, subjected to accident, nuisance, flood, fire or acts of God, or on which any serial numbers have been altered, defaced or removed. NAPCO will not be responsible for any dismantling, reassembly or reinstallation charges.

This warranty contains the entire warranty. It is the sole warranty and any prior agreements or representations, whether oral or written, are either merged herein or are expressly cancelled. NAPCO neither assumes, nor authorizes any other person purporting to act on its

behalf to modify, to change, or to assume for it, any other warranty or liability concerning its products.

In no event shall NAPCO be liable for an amount in excess of NAPCO's original selling price of the product, for any loss or damage, whether direct, indirect, incidental, consequential, or otherwise arising out of any failure of the product. Seller's warranty, as hereinabove set forth, shall not be enlarged, diminished or affected by and no obligation or liability shall arise or grow out of Seller's rendering of technical advice or service in connection with Buyer's order of the goods furnished hereunder.



NAPCO RECOMMENDS THAT THE ENTIRE SYSTEM BE COMPLETELY TESTED WEEKLY.

**Warning:** Despite frequent testing, and due to, but not limited to, any or all of the following; criminal tampering, electrical or communications disruption, it is possible for the system to fail to perform as expected. NAPCO does not represent that the product/system may not be compromised or circumvented; or that the product or system will prevent any personal injury or property loss by burglary, robbery, fire or otherwise; nor that the product or system will in all cases provide adequate warning or protection. A properly installed and maintained alarm may only reduce risk of burglary, robbery, fire or otherwise but it is not insurance or a guarantee that these events will not occur. CONSEQUENTLY, SELLER SHALL HAVE NO LIABILITY FOR ANY PERSONAL INJURY, PROPERTY DAMAGE, OR OTHER LOSS BASED ON A CLAIM THE PRODUCT FAILED TO GIVE WARNING. Therefore, the installer should in turn advise the consumer to take any and all precautions for his or her safety including, but not limited to, fleeing the premises and calling police or fire department, in order to mitigate the possibilities of harm and/or damage.

NAPCO is not an insurer of either the property or safety of the user's family or employees, and limits its liability for any loss or damage including incidental or consequential damages to NAPCO's original selling price of the product regardless of the cause of such loss or damage.

Some states do not allow limitations on how long an implied warranty lasts or do not allow the exclusion or limitation of incidental or consequential damages, or differentiate in their treatment of limitations of liability for ordinary or gross negligence, so the above limitations or exclusions may not apply to you. This Warranty gives you specific legal rights and you may also have other rights which vary from state to state.

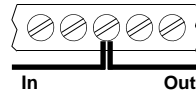
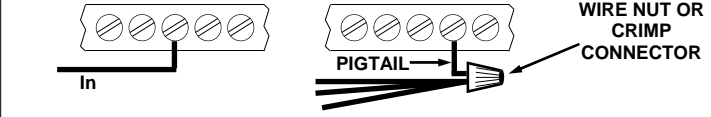
## IMPORTANT WIRING METHODS

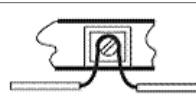
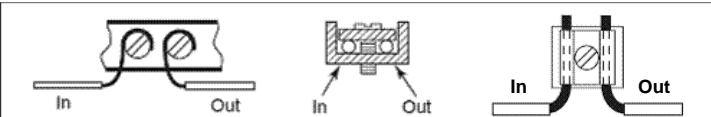
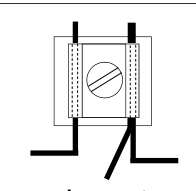
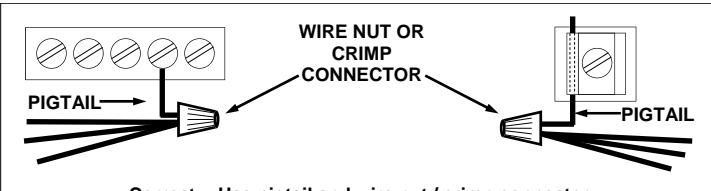
 <p><b>For single-conductor terminal blocks</b> (like the type shown at left), to terminate more than one conductor to a terminal, use the wiring methods shown at right:</p>	 <p><b>Incorrect</b></p>	 <p><b>Correct -- Single incoming and/or pigtail with wire nut / crimp connectors</b></p>
 <p><b>For "barrier" type terminal blocks</b> (like the type shown at left), to terminate two conductors to a terminal, use the wiring methods shown at right:</p>	 <p><b>Incorrect</b></p>	 <p><b>Correct -- Separate incoming and outgoing conductors</b></p>
<p><b>To terminate more than two conductors</b> or conductors of different wire sizes to a terminal, use the "pigtail" type wiring method as shown at right. Use insulated wire for the pigtail, and firmly secure the conductors to the pigtail using an appropriate wire nut or crimp connector for the number and gauge of conductors used.</p>	 <p><b>Incorrect</b></p>	 <p><b>Correct -- Use pigtail and wire nut / crimp connector</b></p>