



i³ Series

3825 Ohio Avenue, St. Charles, Illinois 60174
 1-800-SENSOR2, FAX: 630-377-6495
 www.systemsensor.com

RRS-MOD Reversing Relay/Synchronization Module

SPECIFICATIONS

Operating Voltage Range:	8.5 to 35 VDC
Maximum Operating Current:	25mA
Relay Contacts:	2A at 35 VDC
Operating Temperature Range:	32° to 131° F (0° to 55° C)
Operating Humidity Range:	5% to 93% non-condensing
Dimensions:	2 1/2" x 2 1/2" x 1"
Wire connections:	18 AWG stranded, tinned, 16" long

NOTE: In an alarm condition, a wiring-fault trouble state may also register at the panel when the RRS-MOD is used.

GENERAL DESCRIPTION

The RRS-MOD polarity reversing relay/synchronization module is intended for use with 2-wire and 4-wire i3 series detectors equipped with a built-in sounder, models 2WTA-B, 4WTA-B, 4WTAR-B, and 4WITAR-B. It is designed to allow all the detectors in the same loop to sound when one of the detectors goes into alarm, and to synchronize their audible output. The RRS-MOD also allows the silencing of the detector sounders from the alarm control panel.

The RRS-MOD may be used with an alarm zone that provides coded output for fire and continuous output for burglary. By default the RRS-MOD's switch is set to "off". Therefore, the RRS-MOD will only trigger when the alarm output is coded. In this manner, smoke detectors will only sound from the result of a fire, and not from a burglary alarm. In this mode, the detectors will provide a synchronized, coded output. The RRS-MOD contains a relay that is meant for zone applications, per UL 864.

The RRS-MOD can also be set to only trigger on continuous alarm zone signals by selecting the switch to "on". In this mode, the detectors will provide a synchronized, coded output.

NOTICE: This manual shall be left with the owner/user of this equipment

INSTALLATION

Install in a dry indoor location. Choose a mounting location in the control panel within reach of the provided wire leads. Use a water/isopropyl alcohol mixture (50/50) to clean the mounting surface. Allow surface to dry and remove paper backing from the Velcro and catch. Stick the Velcro in the panel and the catch on the back of the module, then mount the module inside the control panel. Route terminals to the appropriate terminals as noted below.



When calculating total current draw of the control panel, remember to add current consumption (25mA) for the polarity reversal relay module (RRS-MOD). IMPORTANT: If the fire alarm output signal is coded, set the switch on the RRS-MOD to "OFF". If the fire alarm output signal is continuous, set the switch to "ON".

WIRING

IMPORTANT: All polarities must be observed!

1. Connect the RRS-MOD module trigger wire to the fire alarm output terminals.
 - A. Alarm/Bell output: (Figures 1 and 2)
Connect the purple wire to the Alarm or Bell output.
 - B. Alarm relay, normally open contact: (Figures 3 and 4)
 1. Connect one end of the alarm relay contact output to positive auxiliary or detector power fire alarm output.
 2. Connect the purple wire to the other end of the alarm relay contact output.
2. Connect the red and black wires to the panel auxiliary or detector power (red to positive, black to negative).
3. **2-wire models**
Connect the yellow and orange wires to the panel initiating circuit (yellow to positive, orange to negative).
- 4-wire models**
Connect the yellow and orange wires to the panel detector power circuit (yellow to positive, orange to negative).
4. **2-wire models**
Connect the brown and white wires to the smoke detector power supply input (brown to positive, white to negative).
- 4-wire models**
Connect the brown and white wires to the smoke detector power circuit (brown to positive, white to negative).

NOTE: Please refer to Figures 5 and 6 for Ademco Vista panels and Figures 7 and 8 for DSC Power 832 panels.

FIGURE 1. 2-WIRE SYSTEM TRIGGERED FROM ALARM/BELL OUTPUT:

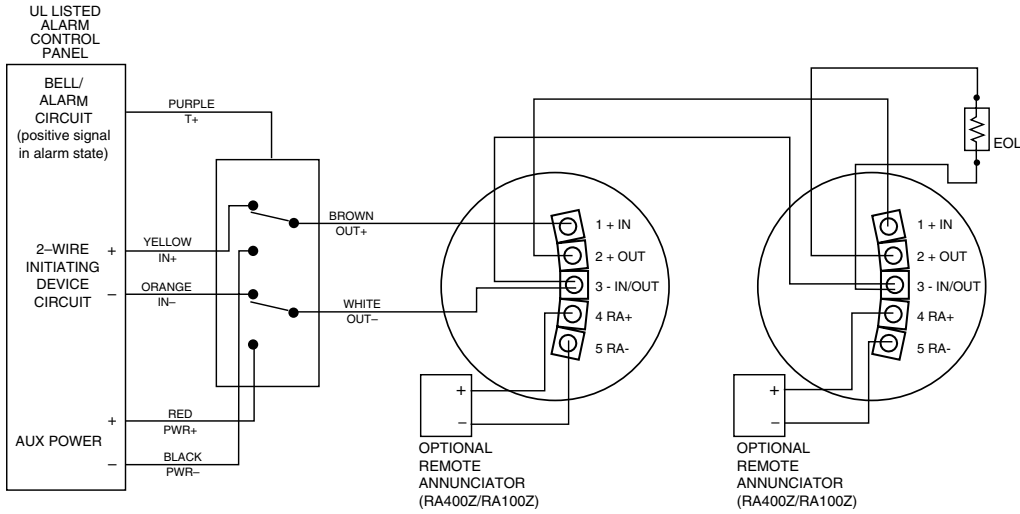

CAUTION

When using the RRS-MOD with model 2WTA-B, do not mix the 2WTA-B with other model smoke detectors and dry contact closure devices, including mechanical heat detectors, manual pull stations and waterflow switches. Such mixing can cause a direct short on the auxiliary power terminals, damaging the control panel's internal circuitry and/or damaging devices connected to the initiating device circuit.

S0101-01

FIGURE 2. 4-WIRE SYSTEM TRIGGERED FROM ALARM/BELL OUTPUT:

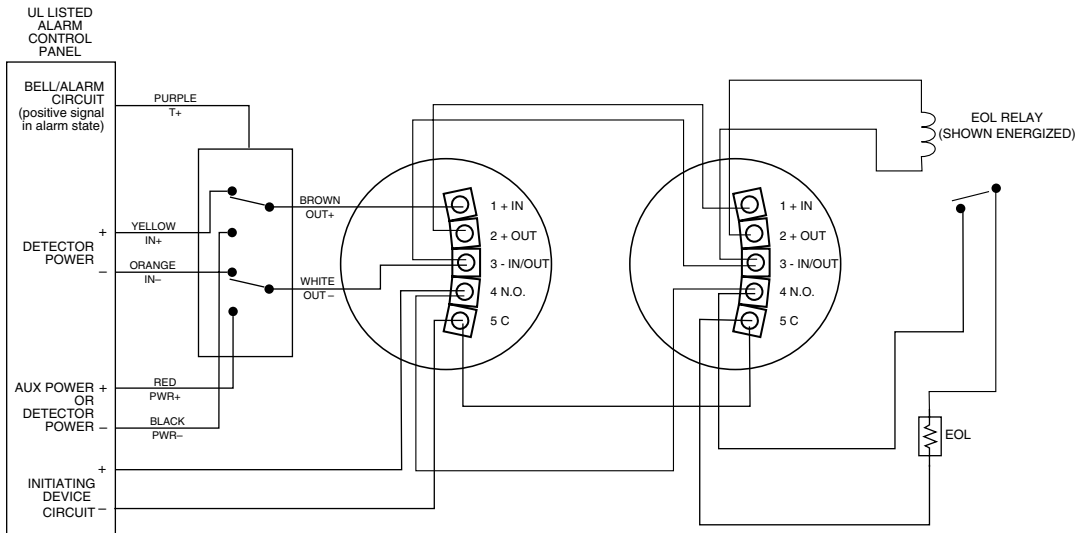

S0102-00

FIGURE 3. 2-WIRE SYSTEM TRIGGERED FROM ALARM RELAY CONTACT:

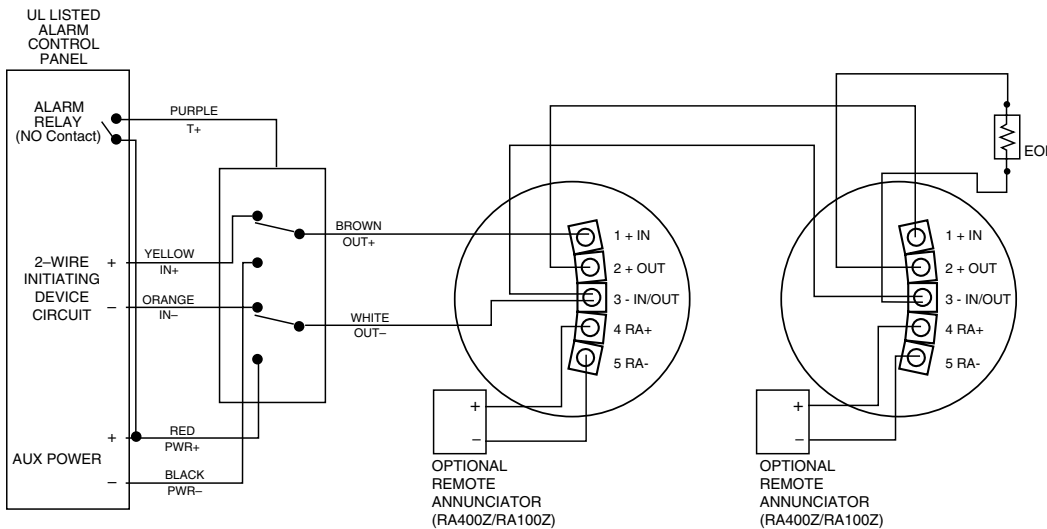

S0103-01

FIGURE 4. 4-WIRE SYSTEM TRIGGERED FROM ALARM RELAY CONTACT:

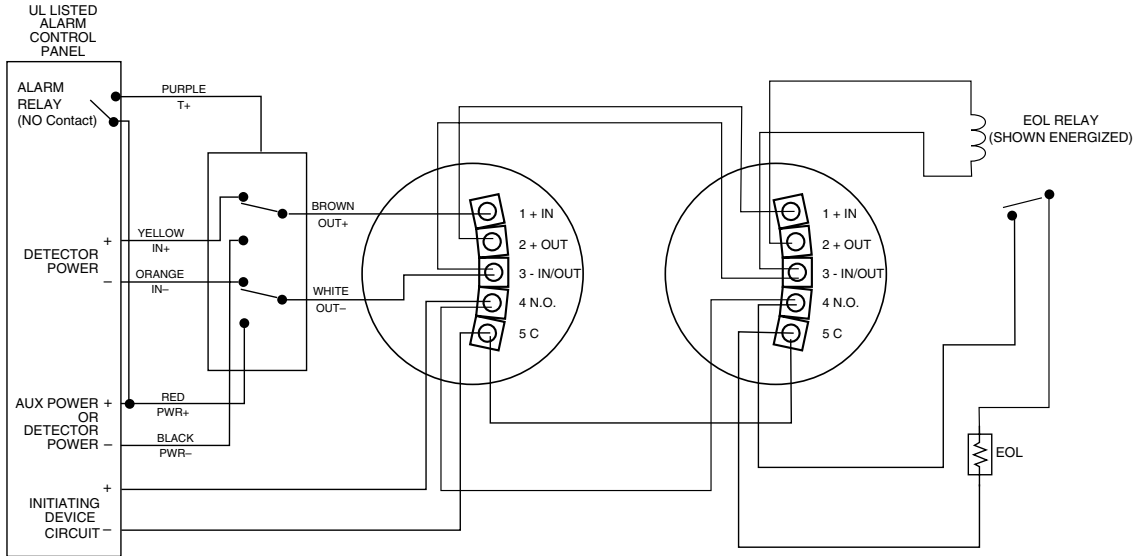

S0104-00

CONNECTION DIAGRAMS WITH ADEMCO VISTA PANELS

The connection diagrams enclosed show how to connect the 2WTA-B model smoke detector to the Vista panels using the System Sensor polarity reversal relay module (RRS-MOD). Please make sure that the smoke detectors are connected properly to the zones specified in the wiring diagrams for proper operation of the smoke detectors.

FIGURE 5. CONNECTING 2WTA-B SMOKE DETECTORS TO ADEMCO CONTROLS USING RRS-MOD MODULE TRIGGERED FROM BELL/ALARM CIRCUIT:

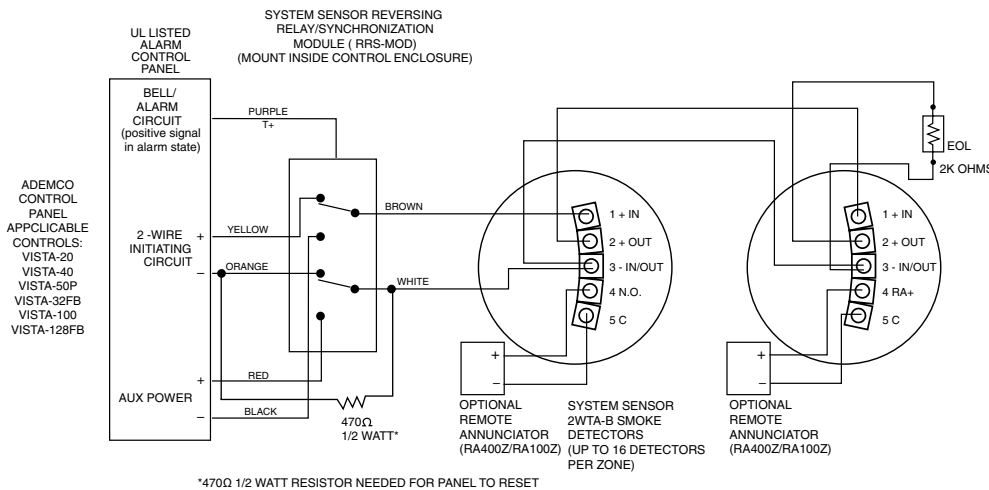

Programming information:

- The supervisory feature for the bell circuit must be turned off. See applicable control manual for procedure.

RRS-MOD Configuration:

- Set switch on RRS-MOD to "OFF".

S0105-02

FIGURE 6. CONNECTING 2WTA-B SMOKE DETECTORS TO ADEMCO CONTROLS USING RRS-MOD MODULE TRIGGERED FROM AUXILIARY RELAY:

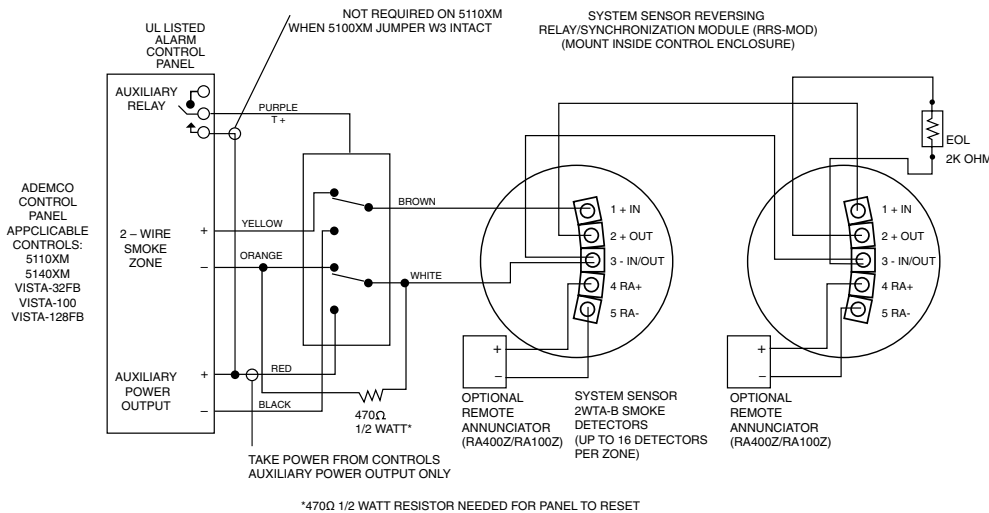

Programming information:

- Program Auxiliary relay to activate on alarms
- Assign Auxiliary relay as an output for zones programmed for fire alarm response only (Types 9, 16, or 17)

RRS-MOD Configuration:

- Set switch on RRS-MOD to "ON".

S0106-02

CONNECTION DIAGRAMS WITH DSC POWER 832 PANELS

FIGURE 7. CONNECTING 4WTA-B, 4WTAR-B, AND 4WITAR-B SMOKE DETECTORS TO DSC POWER 832 CONTROLS USING RRS-MOD MODULE WITH PGM OUTPUT:

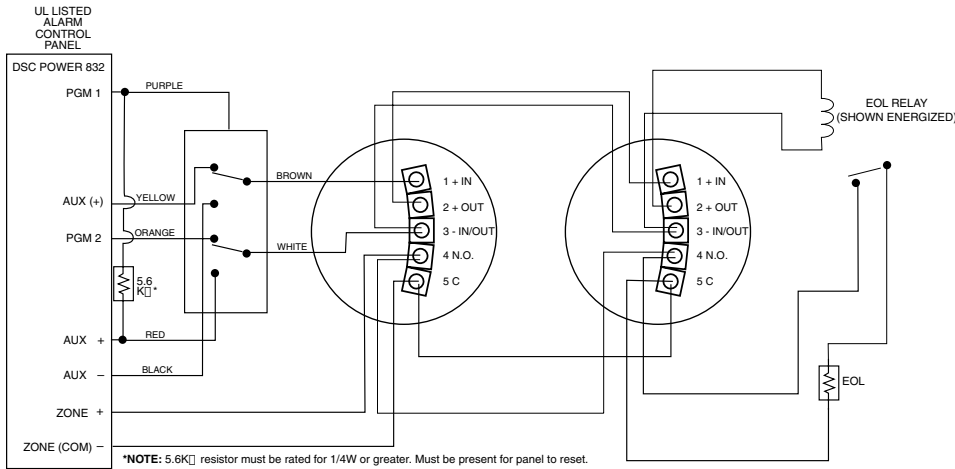

All smoke detectors on the 4-wire fire zone will be synchronized in alarm and will sound 1 sec ON, 1 sec OFF only from a fire alarm event.

NOTE:

- Program zone section attributes for bell output to be pulsing.
- PGM2 must be programmed for sensor reset.
- PGM1 must be programmed as Burglary and Fire Bell Output (01) with ON, ON, OFF attributes.
- RRS-MOD switch must be set to OFF (factory default setting).

S0107-02

FIGURE 8. CONNECTING 2WTA-B SMOKE DETECTORS TO DSC POWER 832 CONTROLS USING RRS-MOD MODULE WITH PGM OUTPUT:

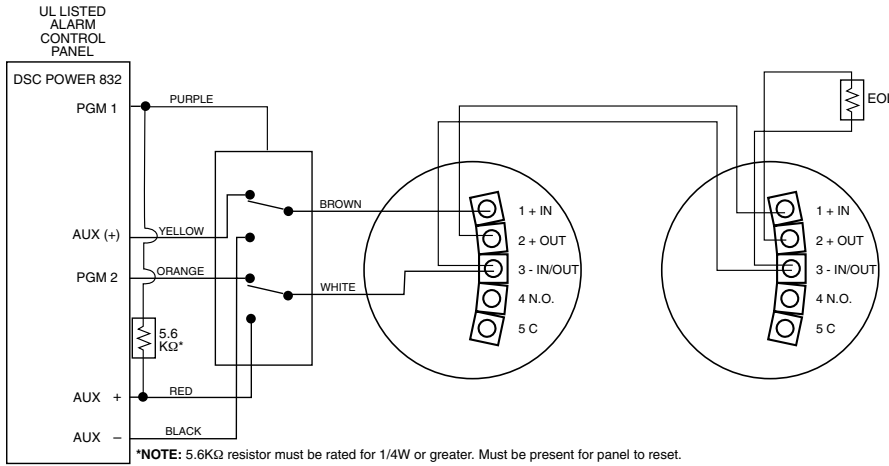

All smoke detectors on the 2-wire fire zone will be synchronized in alarm, and will sound 1 sec ON, 1 sec OFF only from a fire alarm event.

NOTE:

- Program zone section attributes for bell output to be pulsing.
- PGM2 must be programmed for 2-wire smoke zone (04). Jumper J1 on the main board must be removed.
- PGM1 must be programmed as Burglary and Fire Bell Output (01) with ON, ON, OFF attributes.
- RRS-MOD switch must be set to OFF (factory default setting).

S0108-02

TESTING

Before testing, notify the proper authorities that the system is undergoing maintenance and will temporarily be out of service.

Test in accordance with NFPA 72 test methods, inspections, and testing frequency.

1. Confirm that all smoke detectors connected to the RRS-MOD module(s) contain a sounder and the sounders are activated upon power reversal.
2. Initiate an alarm with one of the smoke detectors connected to the RRS-MOD module using any approved test method. In the alarm state, all the detectors connected to the RRS-MOD module must be sounding their sounders.

3. Reset the system from the control panel. All smoke detector sounders should be silent.
4. If the fire alarm panel also functions in burglary, initiate a burglary alarm and ensure the smoke detectors do not sound.

THREE-YEAR LIMITED WARRANTY

System Sensor warrants its enclosed product to be free from defects in materials and workmanship under normal use and service for a period of three years from date of manufacture. System Sensor makes no other express warranty for the enclosed product. No agent, representative, dealer, or employee of the Company has the authority to increase or alter the obligations or limitations of this Warranty. The Company's obligation of this Warranty shall be limited to the replacement of any part of the product which is found to be defective in materials or workmanship under normal use and service during the three year period commencing with the date of manufacture. After phoning System Sensor's toll free number 800-SENSOR2 (736-7672) for a Return Authorization number, send defective units postage prepaid to: System Sensor, Returns Department, RA

_____, 3825 Ohio Avenue, St. Charles, IL 60174. Please include a note describing the malfunction and suspected cause of failure. The Company shall not be obligated to replace units which are found to be defective because of damage, unreasonable use, modifications, or alterations occurring after the date of manufacture. In no case shall the Company be liable for any consequential or incidental damages for breach of this or any other Warranty, expressed or implied whatsoever, even if the loss or damage is caused by the Company's negligence or fault. Some states do not allow the exclusion or limitation of incidental or consequential damages, so the above limitation or exclusion may not apply to you. This Warranty gives you specific legal rights, and you may also have other rights which vary from state to state.