



# 60-924-RF-TS Simon XT Talking Touch Screen Installation Sheet

## Description

The Simon XT Talking Touch Screen (models 60-924-RF-TS and 60-924-RF-TS-N without power supply) features a color 3.5 inch LCD screen with a graphical user interface designed to control basic functionality of the Simon XT (v1.3 or later) control panel. Up to four touch screens can be learned (programmed) into each Simon XT panel.

The touch screen provides a convenient option for the following system operations:

- Arm the system (doors, windows, and motion sensors).
- Disarm the system.
- Activate a panic alarm to call the central monitoring station in a nonmedical emergency.
- Check system status.
- Turn system controlled lights on or off (depending on your system configuration).
- Lock and unlock system-controlled door locks (depending on your system configuration).
- Hear voice feedback of the status of the Simon XT control panel.

## Installation

Use the following guidelines when adding this touch screen to the Simon XT system:

- The touch screen should be the last sensor programmed (learned) into the panel.
- Program (learn) the touch screen into the panel as a sensor.
- Program touch screens using sensor groups 00, 01, 04, 05, 06, or 07.
- The touch screen will work best if mounted greater than 3 ft. (approximately 1 m) from the Simon XT panel.
- Avoid mounting the touch screen directly behind the Simon XT panel on the opposite side of the wall.
- Always do a sensor test before attaching the touch screen to the wall.
- Do not wrap the antenna into the backplate. Follow the instructions to install the antenna into the wall.

## Sensor naming

Please use the following as a guide when naming sensors:

- Sensor names must have the word “window” or “door” from the text library to interact with the touch screen Doors and Windows icons on the Main screen.
- The Motion icon is controlled by sensors that are programmed into the following groups: 15, 17, 18, 20, 28, 32.
- The Property icon is controlled by the following sensors:
  - All sensors learned into Group 43.
  - Sensors that are not named “window” or “door”.
  - Sensors not learned into the Motion groups.
  - Sensors that are named keyfob or keychain.

## To program (learn) the touch screen into the panel:

1. Press the down arrow button on the panel and scroll to System Programming.
2. Press OK.  
The panel displays `Enter Code`.
3. Enter the installer access code and press OK.
4. Scroll to Sensors and press OK.
5. When the panel displays `Learn Sensor`, press OK.  
The panel blinks `Trip Sensor nn` (where nn is the next available zone number). You can enter a different zone number if desired.
6. On the touch screen:
  - A. Press the Settings button.
  - B. Press the Down arrow until the Clear and Enroll button appears.
  - C. Press the Clear and Enroll button. The touch screen should indicate it is waiting for enrollment.
7. On the panel, you can now program the group number (00, 01, 04, 05, 06, or 07) and press OK.
8. On the panel, press the Up or Down arrow to select a name for the touch screen and press OK. (Refer to the Simon XT installation instructions for programming sensor text.)  
You can select something simple, such as “Touch Pad”, or use additional descriptors, such as “Bedroom Touch Pad”.  
The touch screen will indicate enrollment success or failure.

**Note:** During install mode, it is normal for the four blue LEDs on the panel to blink as this indicates the panel is updating the touch screen status. Do not leave program mode if you have modified sensor information or are downloading a company logo while the four blue arming LEDs on the panel are blinking (this may disrupt configuration).

9. To verify that the touch screen is programmed (learned), press the Status button on the panel repeatedly to leave system programming and return to normal panel operation.
10. Press the Settings button on the touch screen and press the Hear button.

The touch screen should announce the panel arming level and status, such as *Disarmed System Okay*.

Refer to your Simon XT panel documentation for other programming options.

**Note:** If you would like this touch screen operation to be code protected, you can enable this feature by following these steps:

1. Select the Settings menu.
2. Scroll to “Code Required Access” and select Yes.

With code required access, not all icons will be displayed.

### Sensor test

The touch screen is sensitive to its orientation to the control panel. For that reason, we recommend you test the touch screen before you mount it on the wall.

### To test the touch screen with the Simon XT (v1.4) panel:

In the Setting menu, press the Test button under RF Test. If less than three bars appear, see “To relocate the touch screen.” below.

### To test the touch screen with the Simon XT (v1.3) panel:

1. Make sure the panel is disarmed.
2. Press the down arrow button on the panel and scroll to System Programming.
3. Press OK.
4. When the panel displays `Enter Code`, enter the appropriate code and press OK.
5. Scroll until the panel displays `Sensor Test`, press OK to start the sensor test.

The panel will prompt you to trip each sensor one at a time.

6. To trip the touch screen, press the Emergency button.

You can follow the panel voice prompting to test the sensors in any order. You should hear the panel beep the number of packets received. The panel will also display the number of packets received. If you do not hear 6 to 8 panel beeps, see “To relocate the touch screen.” below.

You should also perform the following to validate the touch screen installation:

1. Arm the panel and verify that the panel and touch screen indicate that the panel is armed.

2. Wait 10 minutes and verify that you do not get a “loss of connection” message and that the RF icon is not red.

For both Simon XT v1.3 and v1.4, we recommend that you test the touch screen after all programming is completed and whenever a touch screen related problem occurs.

To verify communication between the panel and the touch screen, exit programming mode and then press the System Status icon on the touch screen. The touch screen should announce the correct system status.

### To relocate the touch screen:

1. Test the touch screen a few inches from the original position.
2. Increase the distance from the original position. Retest until an acceptable location is found.
3. Mount the touch screen in the new location (see Mounting).

**Note:** If you cannot get the touch screen to trip, test a known good touch screen at the same location. If the replacement touch screen functions, contact UTC Fire & Security for repair or replacement of the faulty touch screen.

### To mount the touch screen:

1. Remove the touch screen from the mounting base by inserting a small screwdriver into the slot on the bottom of the touch screen (see Figure 1 on page 3).
2. Hold the base on the wall at the mounting location and mark the mounting holes, antenna drop, and power drop.
3. Drill 1/8 inch holes into the wall for plastic anchors at the mounting hole locations. Cut both the antenna and power wire drop openings to the size of the opening in the base.
4. Push the two plastic anchors into the drilled holes and tighten screws within a ¼ inch of the anchors.
5. Feed the power supply plug through the power wire opening.
6. Hang the base over the screws, level, and tighten the screws.
7. Load four AAA batteries into the battery compartment on the back of the touch screen.
8. Plug the power into the back of the touch screen, and secure the power wire to the loop with the tie wrap provided.
9. Feed the antenna wire from the back of the touch screen through the rectangular wire drop opening in the wall.
10. Angle the top of the touch screen into the hooks on the top of the base. Start feeding the power cable through the wire drop, and swing the bottom of the touch screen into the lower part of the base until you hear it click.

**Note:** If necessary, use a soft cloth to clear smudges on the screen; do not use glass cleaner on the screen.

Figure 1: Mounting

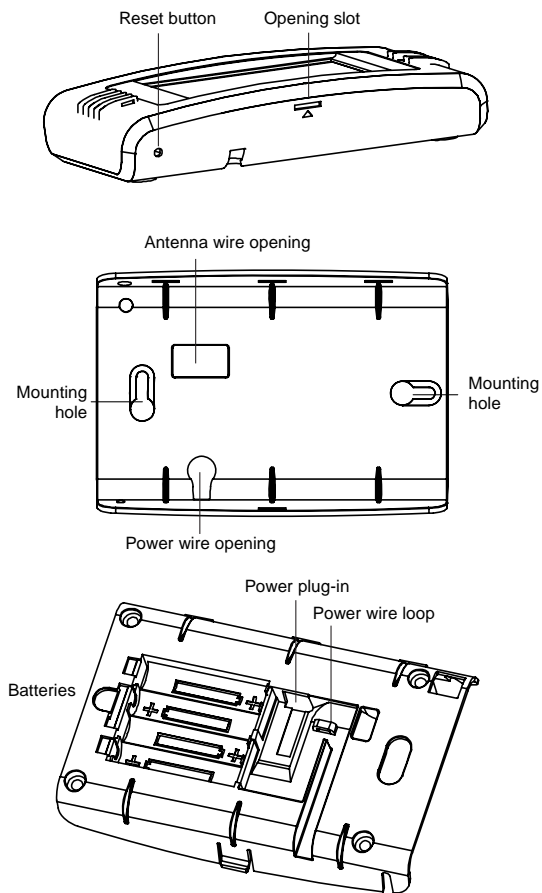

## Operation

Refer to the Simon XT Touch Screen Quick Operation Guide for basic touch screen operation information. Refer to the panel documentation for complete Simon XT programming and operation information.

### Setting the clock

You can set the touch screen clock by setting the clock on the Simon XT panel.

## Battery replacement

When the touch screen batteries are low, the touch screen will display the red battery icon on the Home and Settings screens.

**Note:** We recommend that you replace the batteries once a year and after any significant power outage.

1. Remove the touch screen from the mounting plate by inserting a small screwdriver into the slot on the bottom of the touch screen.
2. Replace all batteries being sure to follow the polarity instructions (see Specifications for recommended batteries).

Avoid touching the touch screen face while you are replacing the batteries.

3. Briefly disconnect the AC power (this will clear the battery fault).
4. Reconnect AC power.

**Note:** If AC power is lost and batteries are not present or are depleted, the touch screen will not power up until AC power is restored (even if new batteries are installed).

## Reset button

The Reset button is located on the bottom left side of the touch screen mounting plate (see Figure 1 above). To power cycle the touch screen, use a toothpick to depress the recessed Reset button.

**Note:** Do not press the Reset button while in programming mode.

## Clear operation

If the Simon XT panel is connected to an online service, some information (such as a dealer logo) can be stored in the touch screen memory. To erase touch screen memory and restore to factory default, simply relearn the touch screen into the panel again. The learn in process begins by clearing the touch screen memory. To keep memory clear, learn the touch screen into a Simon XT panel that has no online service supported.

## Troubleshooting

- If your touch screen fails to enroll, go to the Simon XT panel, delete that touch screen from the panel, and then repeat the enroll procedure.
- If the touch screen chime does not announce the zone name completely, it is likely due to the zone information not being sent to the touch screen during installation. To correct the problem, delete the touch screen and relearn the touch screen again.
- Red text on the Door Lock page indicates an open door or a door that is not monitored.

## Specifications

---

Compatibility	Simon XT (version 1.3 and later)
Power	6 VDC, 500 mA
Batteries	Four 1.5 V, Alkaline, AAA
Dimensions (W × H × D)	5.5 × 3.6 × 1.1 in. (140 × 92 × 28 mm)
Color	White
Operating environment	
Temperature	32 to 104°F (0 to 40°C)
Relative humidity	0 to 90% noncondensing

---

## Regulatory information

---

FCC	<p>This device complies with part 15 of the FCC rules. Operation is subject to the following conditions:</p> <ol style="list-style-type: none"><li>1. This device may not cause harmful interference.</li><li>2. This device must accept any interference received, including interference that may cause undesired operation.</li></ol> <p>Changes or modifications not expressly approved by the party responsible for compliance could void the user's authority to operate the equipment.</p> <p>FCC ID: B4Z-924-2WTTS IC: 1175C-9242WTTS</p>
-----	---

---

## Contact information

For contact information see [www.Interlogix.com](http://www.Interlogix.com)

GE and the GE monogram are trademarks of the General Electric Company and are under license to Interlogix a UTC Fire & Security Company, 9 Farm Springs Road, Farmington, CT 06034-4065.