

# TruVision HD-TVI 5MPX Camera Installation and Configuration Manual



# Contents

## **Introduction 5**

### **Product overview 5**

HD-TVI fixed lens bullet camera: 5

HD-TVI VF motorized lens bullet camera: 5

HD-TVI fixed lens turret camera: 5

HD-TVI VF motorized lens turret camera: 6

HD-TVI VF motorized lens dome camera: 6

## **Installation 7**

### **Installation environment 7**

### **Package contents 10**

HD-TVI fixed lens bullet camera 10

HD-TVI VF motorized lens bullet camera 12

HD-TVI fixed lens turret camera 14

HD-TVI VF motorized lens turret camera 17

HD-TVI VF motorized lens dome camera 19

### **Camera description 22**

### **Mounting the HD-TVI fixed lens bullet camera 28**

Surface mount 28

Surface mount when using the optional back box 30

Mounting the HD-TVI VF motorized lens bullet camera 34

Surface mount when not using the supplied back box 34

Surface mount when using the back box 37

Mounting the HD-TVI fixed lens turret camera 40  
Surface mount 40

Surface mount when using the optional back box 45

Mounting the HD-TVI VF motorized lens turret camera 48

Surface mount 48

Surface mount when using the optional back box 53

Mounting the HD-TVI VF motorized lens dome camera 57

Surface mount 57

## **Programming 61**

Call up the camera OSD menu 62

Menu trees 64

TVB-2409/4409 and TVT-2403/4403 cameras 65

TVB-2410/4410, TVT-2404/4404, and TVD-  
2406/4406 cameras 66

## **Configuration 67**

Output Mode 67

Focus 69

Language 69

Main Menu 70

    Exposure 70

    White Balance 74

    Day/Night 75

    Video Settings 77

    Reset 79

    Save & Exit 79

**Specifications 80**

**Legal and regulatory information 83**

# Introduction

## Product overview

This is the installation guide for TruVision 5MPX HD-TVI camera models:

### **HD-TVI fixed lens bullet camera:**

- TVB-2409 (5MPX Bullet, 3.6 mm lens, PAL)
- TVB-4409 (5MPX Bullet, 3.6 mm lens, NTSC)

### **HD-TVI VF motorized lens bullet camera:**

- TVB-2410 (5MPX Bullet, 2.8 to 12 mm lens, PAL)
- TVB-4410 (5MPX Bullet, 2.8 to 12 mm lens, NTSC)

### **HD-TVI fixed lens turret camera:**

- TVT-2403 (5MPX Turret, 2.8 mm lens, PAL)
- TVT-4403 (5MPX Turret, 2.8 mm lens, NTSC)

## **HD-TVI VF motorized lens turret camera:**

- TVT-2404 (5MPX Turret, 2.8 to 12 mm lens, PAL)
- TVT-4404 (5MPX Turret, 2.8 to 12 mm lens, NTSC)

## **HD-TVI VF motorized lens dome camera:**

- TVD-2406 (5MPX Dome, 2.8 to 12 mm lens, PAL)
- TVD-4406 (5MPX Dome, 2.8 to 12 mm lens, NTSC)



# Installation

This section provides information on how to install the cameras.

## Installation environment

Please keep in mind that there are restrictions/rules when using the HD-TVI 5MPX cameras with TruVision TVI recorders:

- The TVI 5MPX cameras only work with the higher resolution TVI recorders (TVR 15HD or TVR 45HD, or higher), firmware version 1.1 (or higher)
- A maximum number of TVI 5MPX cameras can be supported per TVI recorder
- The TVI 5MPX cameras are only supported on specific ports of the TruVision TVI recorders

## Guidelines:

- TVR 15HD four-channel recorder, v1.1: Supports a maximum of one TVI 5MPX camera on BNC port 1
- TVR 15HD/TVR 45HD eight-channel recorder, v1.1: Supports up to two TVI 5MPX cameras on BNC ports 1 and 2
- TVR 15HD/TVR 45HD 16-channel recorder, v1.1: Supports up to four TVI 5MPX cameras on BNC ports 1, 2, 3 and 4

When installing your product, consider these factors:

- **Electrical:** Install electrical wiring carefully. It should be done by qualified service personnel. Always use a proper 12 VDC or 24 VAC UL listed Class 2 or CE certified power supply to power the camera. Do not overload the power cord or adapter.
- **Ventilation:** Ensure that the location planned for the installation of the camera is well ventilated.

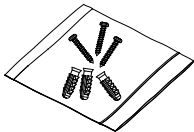
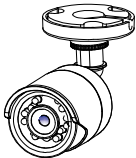
- **Temperature:** Do not operate the camera beyond the specified temperature, humidity or power source ratings. The operating temperature of the camera is between -40 to +60°C (-40 to +140°F). Humidity is below 90% (non-condensing).
- **Moisture:** Do not expose the camera to rain or moisture, or try to operate it in wet areas. Turn the power off immediately if the camera is wet and ask a qualified service person for servicing. Moisture can damage the camera and also create the danger of electric shock.
- **Servicing:** Do not attempt to service this camera yourself. Any attempt to dismantle this product will invalidate the warranty and may also result in serious injury. Refer all servicing to qualified service personnel.
- **Cleaning:** Do not touch the sensor modules with fingers. If cleaning is necessary, use a clean cloth with some ethanol and wipe the camera gently. If the camera will not be used for an extended period of time, put on the lens cap to protect the sensors from dirt.

## Package contents

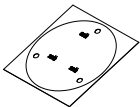
Check the package and contents for visible damage. If any components are damaged or missing, do not attempt to use the unit; contact the supplier immediately. If the unit is returned, it must be shipped back in its original packaging.

### HD-TVI fixed lens bullet camera

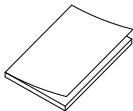
- Camera with power and video output cable harness (cables not shown)
- 3 screws (4 × 25 mm) and 3 anchors (7.5 × 24.5 mm)



- Mounting template



- Installation guide



- 12 VDC connector:  
Two terminal  
connector with  
positive and  
negative indicators



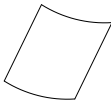
- Torx wrench



- CD

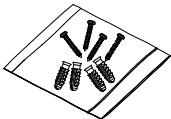
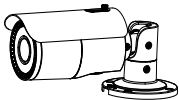


- Equipment  
disposal sheet  
(WEEE directive)



## HD-TVI VF motorized lens bullet camera

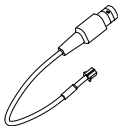
- Camera with power and video output cable harness (cables not shown)
- 4 screws (4 × 25 mm) and 4 (7.5 × 24.5 mm) anchors



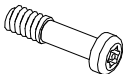
- Torx wrench
- Back box



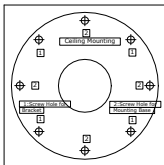
- Video test cable



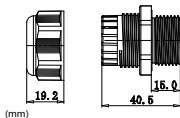
- 4 screws (M4.8 × 18). Used with the back box



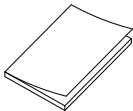
- Mounting template



- Plastic G3/4 cable adapter



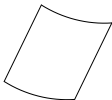
- Installation guide



- CD

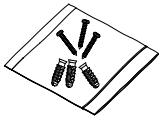
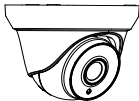


- Equipment disposal sheet (WEEE directive)



## HD-TVI fixed lens turret camera

- Camera with power and video output cable harness (cables not shown)
- 3 screws (4 × 25 mm) and 3 anchors (7.5 × 24.5 mm)

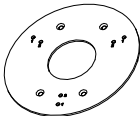




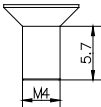
- 12 VDC connector:  
Two terminal connector with positive and negative indicators



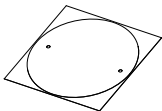
- Adapter plate



- 4 screws (KM4 × 8).  
Used to attach the turret camera to the bracket



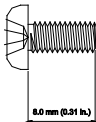
- Mounting template



- 4 screws (PM6-32 × 10).  
Used to attach the turret camera to a 2 gang electrical box



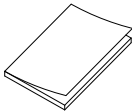
- 3 screws (PM4 × 8).  
Used to attach the turret camera to the adapter)



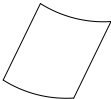
- CD



- Installation guide



- Equipment disposal sheet (WEEE directive)



## HD-TVI VF motorized lens turret camera

- Camera with power and video output cable harness



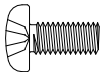
- 3 screws (4 × 25 mm) and 3 anchors (7.5 × 24.5 mm)



- 4 screws (KM4 x 8). Used to attach turret camera to bracket



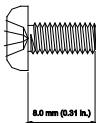
- 4 screws (PM6-32 × 10). Used to attach the turret camera to a 2 gang electrical box



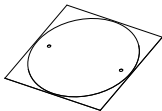
- 12 VDC connector:  
Two-terminal  
connector with  
positive and negative  
indicators



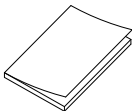
- 3 screws (PM4 x 8). Used to  
attach the turret  
camera to the  
adapter)



- Template



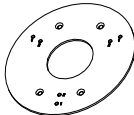
- Installation guide



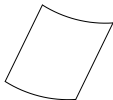
- CD



- Adapter plate

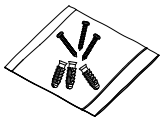
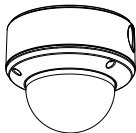


- Equipment disposal sheet (WEEE directive)

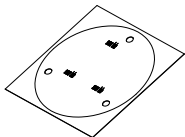


## HD-TVI VF motorized lens dome camera

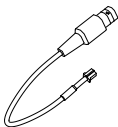
- Camera with power and video output cable harness
- 3 screws (4 × 25 mm) and 3 anchors (7.5 × 24.5 mm)



- Template



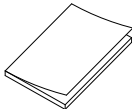
- Video test cable



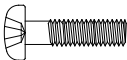
- CD



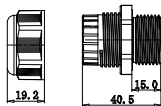
- Installation guide



- 3 screws (PM4 × 16).  
Used to install the camera body on to the dome back box



- Plastic G3/4 cable adapter



(mm)

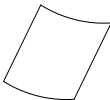
- Torx wrench



- Spare rubber insert

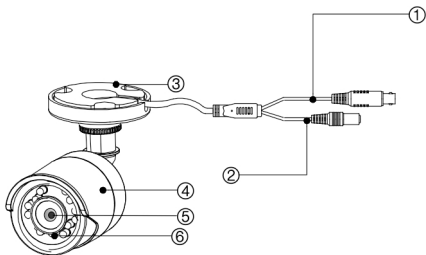


- Equipment disposal sheet (WEEE directive)



## Camera description

Figure 1: HD-TVI fixed lens bullet camera

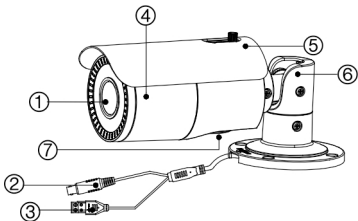


- |                  |                |
|------------------|----------------|
| 1. TVI output    | 4. Camera body |
| 2. 12 VDC power  | 5. Lens        |
| 3. Mounting base | 6. IR LEDs     |

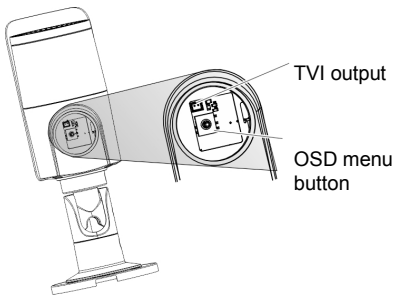


**Figure 2: HD-TVI VF motorized lens bullet camera**

---

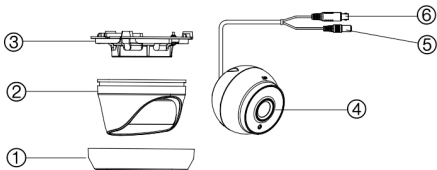


- |                        |   |
|------------------------|---|
| 1. Lens                | 5. Sunshield                                |
| 2. TVI output          | 6. Mounting base                            |
| 3. 12 VDC/24 VAC power | 7. Access to OSD menu button and TVI output |
| 4. Camera body         |   |



**Note:** When making adjustments to the motorized lens bullet camera, it is important to tighten the access cover (7) for the area that contains the video test cable connector and OSD menu button. The access cover should be rotated until it is tight up against the camera body.

**Figure 3: HD-TVI fixed lens turret camera**

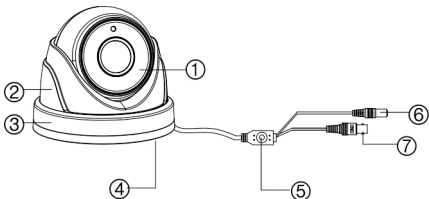


1. Trim ring
2. Housing
3. Base

4. Lens assembly
5. 12 VDC power
6. TVI output

**Figure 4: HD-TVI VF motorized lens turret camera**

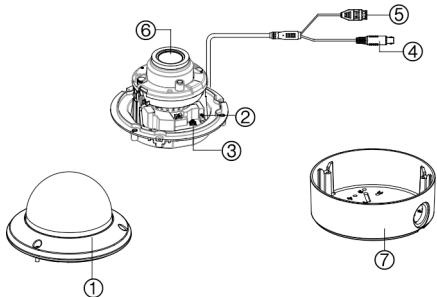
---



1. Lens assembly
2. Housing
3. Trim ring
4. Base

5. OSD (5-direction) button
6. 12 VDC power
7. TVI output

**Figure 5: HD-TVI VF motorized lens dome camera**

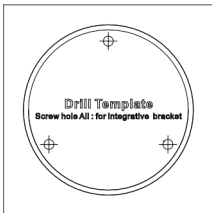


- |                             |                        |
|-----------------------------|------------------------|
| 1. Bubble                   | 5. 12 VDC/24 VAC power |
| 2. Video test cable         | 6. Lens assembly       |
| 3. OSD (5-direction) button | 7. Base                |
| 4. TVI output               |                        |

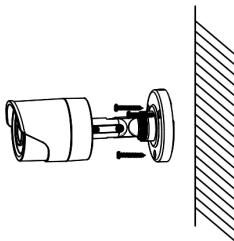
# Mounting the HD-TVI fixed lens bullet camera

## Surface mount

1. Place the provided template level against the mounting surface and mark the position of the mounting holes.

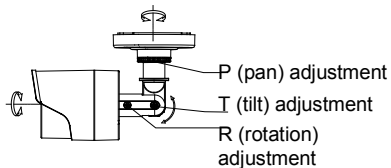


2. Following all local safety regulations, drill and prepare the mounting and cable access (if required) holes.
3. Route the cables through the cable access slot.
4. Secure the camera to the surface with the mounting hardware that was provided.



5. Connect the corresponding cables.
6. Adjust the camera to get the best viewing angle. See the figure below.

Pan position range: 0-360°



Rotation position  
range: 360°

Tilt position range: 0-  
180°

- a) Loosen the P adjustment disk to adjust the pan direction [0-360°]. Tighten the disk after completing the adjustment.
- b) Loosen the T screw to adjust the tilt direction [0-180°]. Tighten the screw after completing the adjustment.
- c) Loosen the R screw and rotate the camera [0-360°] to adjust the lens to the desired surveillance angle. Tighten the screw after completing the adjustment.

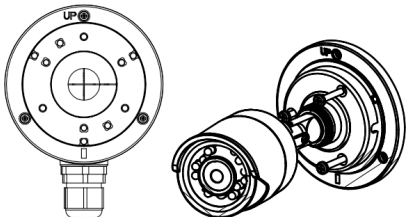
## Surface mount when using the optional back box

**Note:** The fixed lens bullet back box or two gang adapter plate are supplied separately.

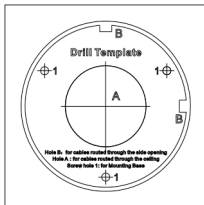
1. Remove the cover from the back box and align the screw holes of the bullet camera with the holes in the back box cover.



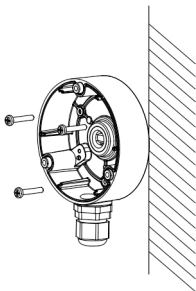
2. Route the cables through the cable access hole of the back box. Mount the camera to the back box cover using the screws provided.



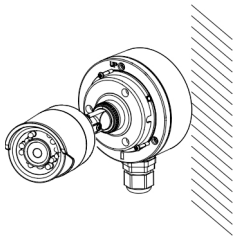
3. Place the mounting template level against the mounting surface and mark the position of the mounting holes. Use the 'UP' marking on the back box and camera mounting base as a reference.



4. Following all local safety regulations, drill and prepare the mounting holes.
5. Install the back box to the mounting surface using the hardware provided.



6. Connect the corresponding cables, and install the back box cover and camera to the back box.

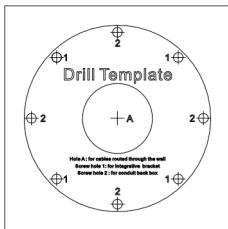


7. Refer to step 6 of “Surface mount” on page 28 to adjust the camera viewing angle.

# Mounting the HD-TVI VF motorized lens bullet camera

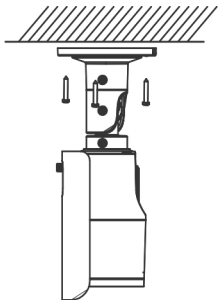
## Surface mount when not using the supplied back box

1. Use the supplied template to mark out the mounting area.

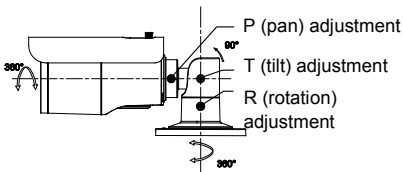


2. Following all local safety regulations, drill and prepare the mounting and cable access (if required) holes.
3. Route the cables through the cable access hole.

- Secure the camera to the mounting surface with the provided hardware.



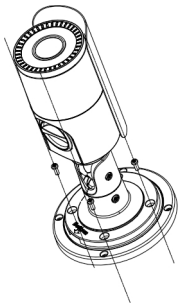
- Connect the corresponding cables.
- Adjust the camera to get the best viewing angle. See the figure below.



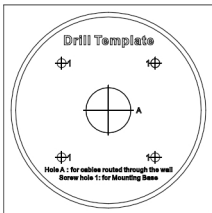
- Loosen the P screw to adjust the pan direction [0-360°]. Tighten the screw after completing the adjustment.
- Loosen the T screw to adjust the tilt direction [0-180°]. Tighten the screw after completing the adjustment.
- Loosen the R screw and rotate the camera [0-360°] to adjust the lens to the desired surveillance angle. Tighten the screw after completing the adjustment.

## Surface mount when using the back box

1. Remove the cover from the back box and align the screw holes of the bullet camera with the holes in the back box cover.
2. Route the cables through the cable access hole of the back box. Install the camera to the back box cover using the screws provided. See figure below.

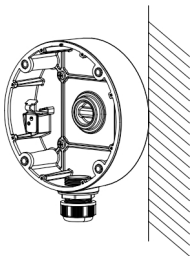


3. Place the provided template level against the mounting surface and mark the position of the mounting holes.

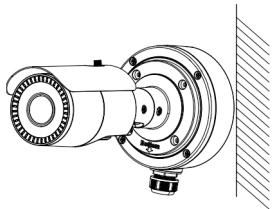


4. Following all local safety regulations, drill and prepare the mounting holes.
5. Install the back box to the mounting surface using the hardware provided.





6. Connect the corresponding cables and install the camera to the back box.



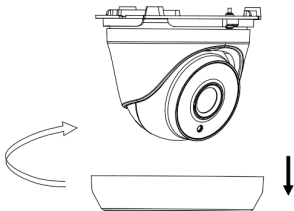
7. Refer to step 6 of “Surface mount when not using the supplied back box” on page

34 to adjust the camera to the desired viewing angle.

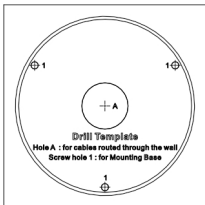
## Mounting the HD-TVI fixed lens turret camera

### Surface mount

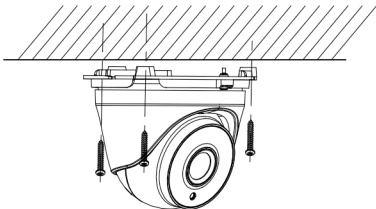
1. Disassemble the turret camera by rotating the trim ring, as shown below.



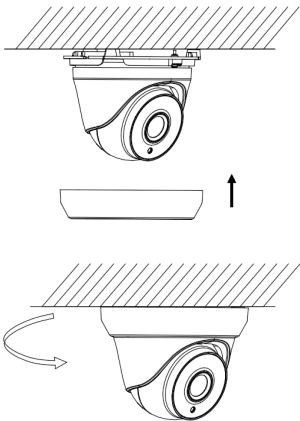
2. Place the provided template level against the mounting surface and mark the position of the mounting holes.



3. Following all local safety regulations, drill and prepare the mounting and cable holes.
4. Route the cables through the cable access hole (if required).
5. Secure the mounting base to the mounting surface with the hardware provided.

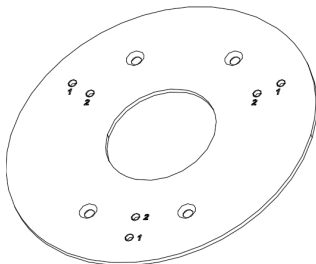


6. Route the cables. Connect the power cord and TVI cables.
7. Reassemble the turret camera by rotating the trim ring back in place.



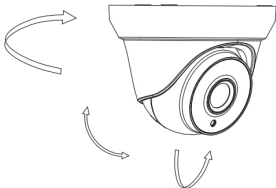
If installing the turret camera to a wall mount or other accessory, an adapter plate is provided. Install the adapter plate

to the accessory with three PM4 x 8 screws, referencing number "2".



8. Adjust the camera to get the best viewing angle. See figure below.

Pan position range: 0-360°



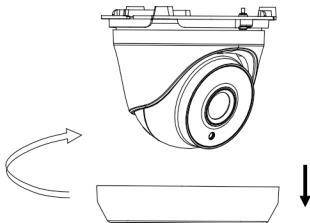
Tilt position range:  
0-75°

Rotation position  
range: 0-360°

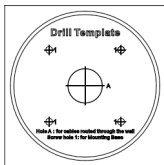
- a) Hold the camera body and rotate the enclosure to adjust the pan angle [0-360°].
- b) Move the camera body up and down to adjust the tilt angle [0-75°].
- c) Rotate the camera body to adjust the azimuth angle [0-360°].

## Surface mount when using the optional back box

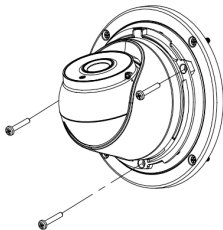
1. Disassemble the turret camera by rotating the trim ring, as shown below.



2. Remove the cover from the back box.
3. Place the provided template level against the mounting surface and mark the position of the mounting holes.
4. Following all local safety regulations, drill and prepare the mounting holes.

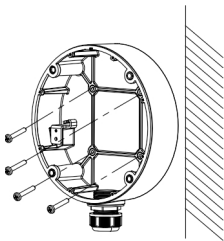


5. Route the cables through the cable access hole of the back box. Mount the camera to the cover of the back box.

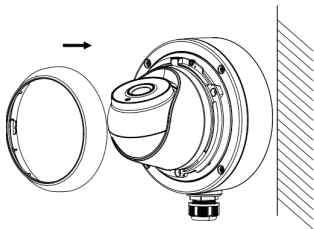


6. Mount the back box to the mounting surface.

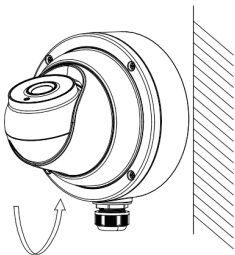




7. Connect the corresponding cables and install the back box cover, with the camera, to the back box.



8. Rotate the trim ring back on to the camera, as shown below.



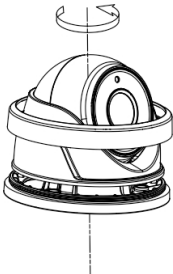
9. Refer to page 43 to adjust the camera to the desired viewing angle.

## **Mounting the HD-TVI VF motorized lens turret camera**

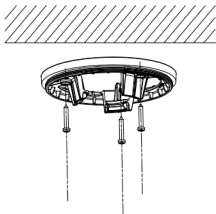
### **Surface mount**

1. Place the provided template level against the mounting surface and mark the position of the mounting holes.
2. Following all local safety regulations, drill and prepare the mounting holes.

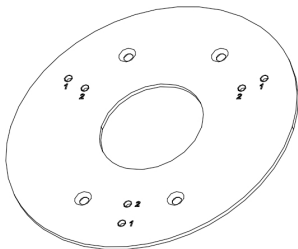
3. Disassemble the turret camera by rotating the trim ring counterclockwise, as shown below.



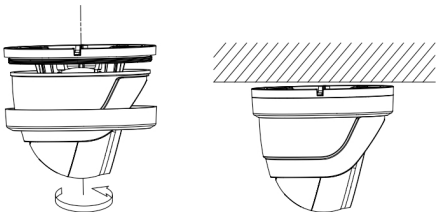
4. Route the cables through the cable access hole (if required).
5. Secure the mounting base to the surface using the screws provided.



There is an adapter plate provided if installing the turret camera to a wall mount or other accessory. Install the adapter plate to the accessory with three PM4 x 8 screws, referencing number "2".



6. Reassemble the turret camera by rotating the trim ring back on the camera, as shown below.



Helpful hints when mounting the turret camera:

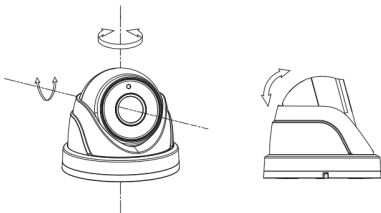
- a) Mount the turret base to a surface.
- b) When mounting on a wall, aim the lens towards the floor and the UP marking on the camera assembly towards the ceiling.
- c) Place the camera eyeball assembly on two of the three standoffs of the mounting base.

- d) Place the turret housing over the camera assembly.
  - e) Place the metal ring over the camera turret housing.
  - f) Hold the turret housing and camera assembly in place with your right hand.
  - g) Using your left hand, rotate the metal ring clockwise to tighten it.
  - h) Prior to completely tightening the ring, aim the camera body/lens towards the desired position.
7. Adjust the camera to get the best viewing angle (see figures below).
- a) Hold the camera body and rotate the enclosure to adjust the pan angle [0-360°].
  - b) Move the camera body up and down to adjust the tilt angle [0-75°].

- c) Rotate the camera body to adjust the azimuth angle [0-360°].

Pan position range:  
0-360°

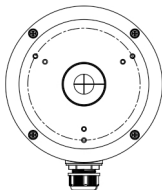
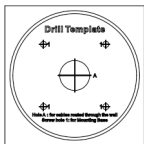
Tilt position range:  
0-75°



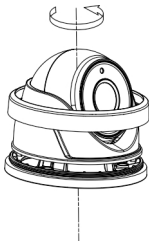
Rotation position range: 0-360°

## Surface mount when using the optional back box

1. Remove the cover from the back box.
2. Place the provided template level against the mounting surface and mark the position of the mounting holes.

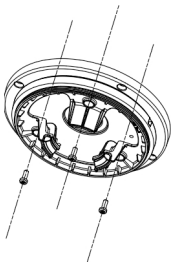


3. Following all local safety regulations, drill and prepare the mounting holes.
4. Disassemble the turret camera by rotating the trim ring counterclockwise, as shown below.

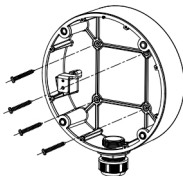




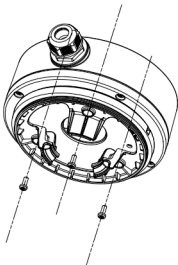
5. Route the cables through the cable access hole of the back box. Mount the camera to the back box.



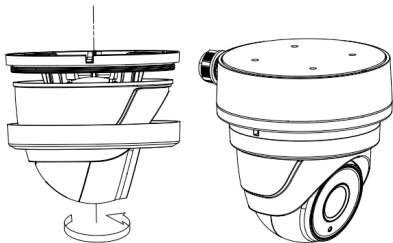
6. Install the back box to the mounting surface using the hardware provided.



7. Connect the corresponding cables and install the back box cover and camera to the back box.



8. Rotate the trim ring back on to the camera body, as shown by the arrow.



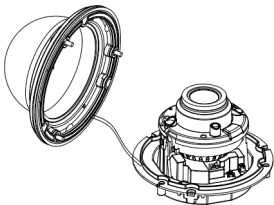
9. Adjust the camera according to step 8 of “Surface mount” on page 48 to get the best viewing angle.

## Mounting the HD-TVI VF motorized lens dome camera

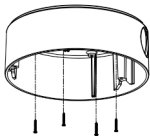
### Surface mount

1. Place the provided template level against the mounting surface and mark the position of the mounting holes.
2. Following all local safety regulations, drill and prepare the mounting holes.

3. Loosen the three screws at the edge of the bubble assembly using the supplied Torx wrench.
4. Remove the bubble.

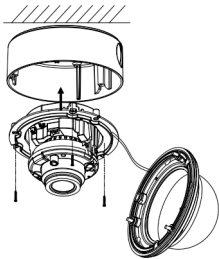


5. Secure the back box to the ceiling with the supplied screws.



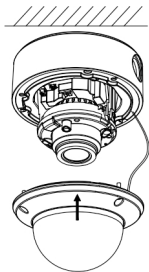
**Note:** Please remove the rubber knockout for cable routing outside of the camera, when required.

6. Using a 75-ohm coaxial video cable, connect the camera TVI video output and a TVI DVR, and connect a 12 VDC or 24 VAC power supply to the power cable, as indicated by the camera.
7. Align the camera assembly with the back box. Use the three screws provided to secure the camera body to the back box.



8. Adjust the surveillance angle:
  - a) View the camera image on a monitor.

- b) Rotate the panning table to adjust the pan direction [0 to 355°].
  - c) Move the lens assembly up or down to adjust the tilt position [0 to 90°].
  - d) Rotate the camera lens holder [0 to 355°] to adjust the lens to the surveillance angle.
9. Reinstall the bubble assembly.



# Programming

Once the camera hardware has been installed, configure the camera using the built-in OSD button (if supported) and the TVI DVR menu. The TVS-C200 controller (Service Tool) does not support the 5MPX cameras.

You can also configure the camera settings via a TVI DVR. Select the PTZ protocol **TruVision Coax** and click the menu button to call up the menu.

When using the TVI output, the 5MPX TVI cameras must be used with the higher resolution (5MPX or higher) TVI DVRs. They are not compatible with lower resolution TVI DVRs.

Please keep in mind that there are restrictions/rules when using the HD-TV 5MPX cameras with TruVision TVI recorders:

- The TVI 5MPX cameras only work with the higher resolution TVI recorders (TVR 15HD or TVR 45HD, or higher), firmware version 1.1 (or higher)

- A maximum number of TVI 5MPX cameras can be supported per TVI recorder
- The TVI 5MPX cameras are only supported on specific ports of the TruVision TVI recorders

#### Guidelines:

- TVR 15HD four-channel recorder, v1.1: Supports a maximum of one TVI 5MPX camera on BNC port 1
- TVR 15HD/TVR 45HD eight-channel recorder, v1.1: Supports up to two TVI 5MPX cameras on BNC ports 1 and 2
- TVR 15HD/TVR 45HD 16-channel recorder, v1.1: Supports up to four TVI 5MPX cameras on BNC ports 1, 2, 3 and 4

## Call up the camera OSD menu

#### To set up the camera:

1. Set up the camera hardware as described in the Installation Manual.
2. In **Camera Settings** of the DVR, access the PTZ menu and set the protocol for the



TruVision HD-TVI camera to **TruVision-Coax**.

3. In live view of the desired camera, click the PTZ Control icon on the live view toolbar to access the PTZ control panel.
4. To call up the camera setup menu:

From the camera, press the **Menu** button (if present).

— or —

From the camera OSD of the DVR, select **Menu**.

— or —

From the DVR, select **Iris+**.

The camera setup menu appears (see “Menu trees” on page 64 for the menu structure).

5. Select the menu options:

**From the DVR:** To select an OSD item, click the directional buttons up/down. To

adjust the value of a selected item, click the directional buttons left/right.

**From the camera (if it has a menu button):** To select an OSD item, push the Menu button up/down. To adjust the value of a selected item, push the Menu button left/right.

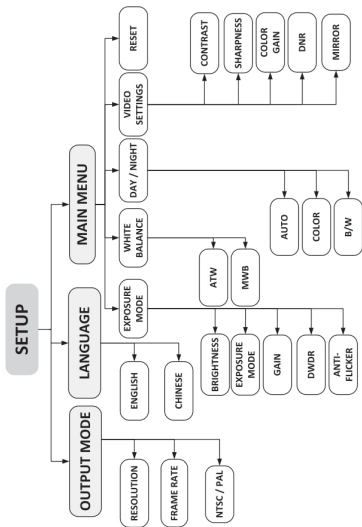
6. Click **Iris+** to enter the submenu or to confirm the selected item.
7. When the setup is complete, select **Exit** and click **Iris+** to exit the camera OSD.

**Note:** You cannot exit the camera setup menu using the Menu button on the camera.

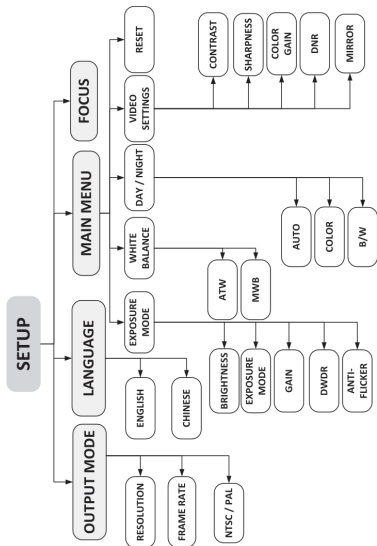
## Menu trees

The menu trees of the TruVision TVI 5MPX cameras are shown below.

# TVB-2409/4409 and TVT-2403/4403 cameras



# TVB-2410/4410, TVT-2404/4404, and TVD-2406/4406 cameras

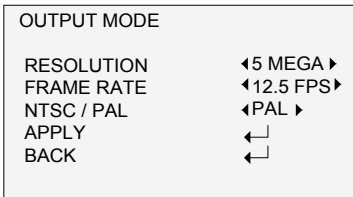


# Configuration

This section describes how to set up the menu settings.

## Output Mode

Move the cursor to **OUTPUT MODE**, and press the Menu button to enter the submenu. Set the RESOLUTION, FRAME RATE, and NTSC/PAL of the camera and confirm.



## RESOLUTION

This is the number of pixels displayed in an image. Set the resolution to 5 megapixels or 1080P. The higher the

value, the finer the image.

## FRAME RATE

This is the number of video images per second.

When the resolution is set to 5 megapixels, set the frame rate to 12.5 fps. When the resolution is set to 1080P, set the frame rate to 25 fps or 30 fps.

## NTSC/PAL

**PAL (Phase Alternating Lines):** It is a color encoding system for analog television used in broadcast television systems in most countries.

**NTSC (National Television System Committee):** It is the analog television system that is used in most of North America, parts of South America, Myanmar, South Korea, etc..

## APPLY

Select to save the settings.

## BACK

Select to return to the main menu.

## Focus

Adjust the focus by clicking FOCUS+ or FOCUS-. Adjust the zoom ratio by clicking ZOOM+ or ZOOM-.

Click the **Zoom+** button to focus in on fewer objects and then click **Focus+** to obtain a clear image. Click the **Zoom-** button to focus out on more objects and then click **Focus-** to obtain a clear image. Adjust the zoom before you adjust the focus.

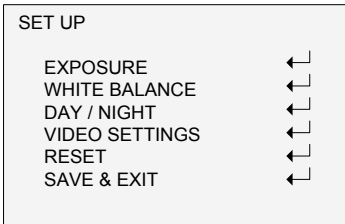
**Note:** As TVB-2409/4409 and TVT-2403/4403 are fixed lens cameras, they do not support this feature.

## Language

Select either ENGLISH or CHINESE as the system language.

## Main Menu

Use the Main menu to adjust the image-related parameters, including **EXPOSURE**, **WHITE BALANCE**, **DAY/NIGHT**, and **VIDEO SETTINGS**.



## Exposure

This describes the brightness-related parameters. Adjust the image brightness using **BRIGHTNESS**, **EXPOSURE MODE**, **GAIN**, **DWDR**, and **ANTI-FLICKER** for different lighting conditions.



EXPOSURE	
BRIGHTNESS	◀ 5 ▶
EXPOSURE MODE	◀ GLOBAL ▶
GAIN	◀ HIGH ▶
DWDR	◀ OFF ▶
ANTI-FLICKER	◀ OFF ▶
BACK	◀ ↵

## BRIGHTNESS

This is the brightness of the image. You can set the brightness value from 1 to 10 to darken or brighten the image. The higher the value, the brighter the image.

## EXPOSURE MODE

Select GLOBAL, BLC, or LV from the menu.

**GLOBAL:** This is the normal exposure mode to use for a wide range of situations to achieve an optimum image.

**BLC:** BLC (Backlight Compensation) improves image quality when the background illumination is high. It prevents the object in the center of the image from appearing too dark. Set the LV value between 1 and 8 to increase the backlight compensation level.

**LV:** LV (level of backlight compensation) is only available when BLC mode is selected.

## GAIN

This optimizes the clarity of the image under poor lighting conditions. Set the gain as **HIGH**, **MIDDLE**, or **LOW**. The higher the gain value, the clearer the image. Select **OFF** to disable the function.

**Note:** Noise will be amplified if gain is enabled.

## AGC

AGC mode (Automatic Gain Control) is a form of amplification where the camera will automatically boost the

image output signal to optimize the clarity of the image in poor lighting conditions. Set the AGC value between 0 and 15. AGC is disabled when the value is set to 0.

## DWDR

DWDR mode (Digital Wide Dynamic Range) helps the camera provide clear images even under backlight circumstances. When there are both very bright and very dark areas simultaneously in the field of view, DWDR balances the brightness level of the whole image and provides clear images with detail.

Set the DWDR as ON to improve the image quality under the backlight environment.

Set the DWDR as OFF to disable the function.

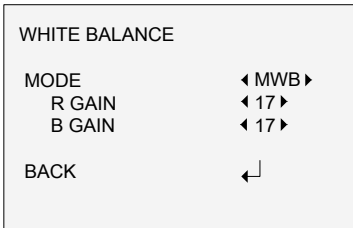
## ANTI- FLICKER

Set the flicker mode as ON to prevent

the image from flickering when the video output is not compatible.

## White Balance

White balance is the white rendition function of the camera to adjust the color temperature according to the environment. It can remove the unrealistic color casts in the image. Select **MWB** and **ATW**.



### MWB

Set the R GAIN/B GAIN value between 0 and 255 to adjust the shades of red/blue color in the image.

## ATW

When ATW mode (auto-tracking white balance) is enabled, white balance is adjusted automatically according to the color temperature of the scene illumination.

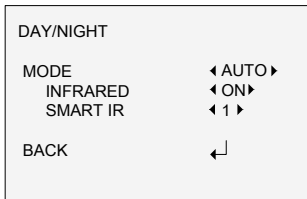
## Day/Night

This function defines whether the camera is in day or night mode. The day (color) option should be used, for example, if the camera is located indoors where light levels are always good.

Set the DAY/NIGHT mode as AUTO, COLOR or B/W.

## AUTO

The image switches from color to B/W or from B/W to color automatically depending on the lighting conditions. You can turn on or off the IR LED depending on the lighting conditions.



**INFRARED:** Select to turn on/off the IR LED depending on the lighting conditions.

**SMART IR:** Use this to avoid over exposure of an image due to IR LED glare. Adjust the **SMART IR** value between 0 and 3. The higher the value, the more obvious the effects. It is disabled when the value is set to 0.

## COLOR

The camera is always in day mode. The image is in color. Use this for normal lighting conditions.

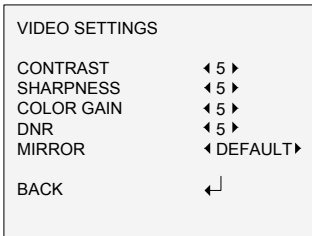
## B/W

The camera is always in night mode. The

image is black and white. The IR LED turns on in low lighting conditions.

## Video Settings

Move the cursor to **VIDEO SETTINGS** and press the confirm button to enter the submenu. Adjust the **CONTRAST**, **SHARPNESS**, **COLOR GAIN**, **DNR** and **MIRROR** values to achieve the desired effect.



### CONTRAST

This function enhances the difference in color and light between parts of an image. Set the value between 1 and 10. The

higher the value, the stronger the contrast.

## SHARPNESS

This function determines the level of detail of an image. Set the value between 1 and 10. The higher the value, the clearer and sharper the image appears.

## COLOR GAIN

Adjust this function to change the color saturation. Set the value between 1 and 10. The higher the value, the clearer the color of the image.

## DNR

DNR (Digital Noise Reduction) reduces noise especially in low lighting conditions to provide a more accurate and sharper image quality. Set the value between 1 and 10. The higher the value, the higher the noise reduction and the clearer the image.

## MIRROR

Use this function to flip the original image



into a mirror image. This could be used, for example, when the camera needs to be installed upside down. Select one of the functions:

**DEFAULT:** The mirror function is disabled.

**H:** The image flips 180 degrees horizontally.

**V:** The image flips 180 degrees vertically.

**HV:** The image flips 180 degrees both horizontally and vertically.

## Reset

Reset all the settings to the default.

## Save & Exit

Move the cursor to **SAVE & EXIT** and press **OK** to save the setting and exit the menu.

# Specifications

---

Power supply 12 VDC / 24 VAC

---

Current **TVB-2409/TVB-4409:**  
12 VDC: Max. 290 mA

**TVB-2410/TVB-4410:**  
12 VDC: Max. 790 mA /  
24 VAC: Max.660 mA

**TVT-2403/TVT-4403:**  
12 VDC: Max. 250 mA

**TVT-2404/TVT-4404:**  
12 VDC: Max. 750 mA

**TVD-2406/TVD-4406:**  
12 VDC: Max. 580 mA /  
24 VAC: 416 mA

---

Power consumption **TVB-2409/TVB-4409:**  
12 VDC: Max. 3.5 W

**TVB-2410/TVB-4410:**  
12 VDC: Max. 9.5 W /  
24 VAC: 9.5 W

---

---

**TVT-2403/TVT-4403:**

12 VDC: Max. 3 W

**TVT-2404/TVT-4404:**

12 VDC: Max. 9 W

**TVD-2406/TVD-4406:**

12 VDC: Max. 7 W /

24 VAC: 7 W

---

Weight (net)

**TVB-2409/TVB-4409:**

370 g / 0.82 lb.

**TVB-2410/TVB-4410:**

900 g / 1.98 lb.

**TVT-2403/TVT-4403:**

350 g / 0.77 lb.

**TVT-2404/TVT-4404:**

750 g / 1.57 lb.

**TVD-2406/TVD-4406:**

1600 g / 3.53 lb.

---

---

Dimensions

**TVB-2409/TVB-4409:**

58.2 × 154.5 mm / 2.3 × 6.08 in.

**TVB-2410/TVB-4410:**

94.7 × 265.4 mm / 3.7 ×  
10.45 in.

**TVT-2403/TVT-4403:**

126.7 × 97.84 mm / 5 × 3.85 in.

**TVT-2404/TVT-4404:**

135.78 × 118.2 mm / 5.35 ×  
4.65 in.

**TVD-2406/TVD-4406:**

145.2 × 124.1 mm / 5.72 ×  
4.89 in.

---

# Legal and regulatory information

## Copyright:

© 2017 United Technologies Corporation. All rights reserved.  
Interlogix is part of UTC Climate, Controls & Security, a unit of United Technologies Corporation.

## Trademarks and patents:

Trade names used in this document may be trademarks or registered trademarks of the manufacturers or vendors of the respective products.

## Manufacturer:

Interlogix

2955 Red Hill Avenue, Costa Mesa, CA 92626-5923, USA

Authorized EU manufacturing representative:

UTC Fire & Security B.V.

Kelvinstraat 7, 6003 DH Weert, The Netherlands

## Certification:



## FCC compliance: Class A

Class A: This equipment has been tested and found to comply with the limits for a Class A digital device, pursuant to part 15 of the FCC Rules. These limits are designed to provide reasonable protection against harmful interference when the equipment is operated in a commercial environment. This equipment generates, uses, and can radiate radio frequency energy and, if not installed

and used in accordance with the instruction manual, may cause harmful interference to radio communications. Operation of this equipment in a residential area is likely to cause harmful interference in which case the user will be required to correct the interference at his own expense.

**FCC conditions:**

This device complies with Part 15 of the FCC Rules. Operation is subject to the following two conditions:

- (1) This device may not cause harmful interference.
- (2) This Device must accept any interference received, including interference that may cause undesired operation.

**ACMA compliance:**

Notice! This is a Class A product. In a domestic environment this product may cause radio interference in which case the user may be required to take adequate measures.

**Canada:**

This Class A digital apparatus complies with CAN ICES-003 (A)/NMB-3 (A).

Cet appareil numérique de la classe A est conforme à la norme CAN ICES-003 (A)/NMB-3 (A).

**European Union directives:**

This product and - if applicable - the supplied accessories too are marked with "CE" and comply therefore with the applicable harmonized European standards listed under the EMC Directive 2014/30/EU, the RoHS Directive 2011/65/EU.



**2012/19/EU (WEEE directive):** Products marked with this symbol cannot be disposed of as unsorted municipal waste in the European Union. For proper recycling, return this product to your local supplier upon the purchase of equivalent new equipment, or dispose of it at designated collection points. For more information see: [www.recyclethis.info](http://www.recyclethis.info).

**Contact information:**

For contact information, see [www.interlogix.com](http://www.interlogix.com) or [www.utcssecurityproducts.eu](http://www.utcssecurityproducts.eu)

