

# INSTALLATION INSTRUCTIONS

## ZC21 TWO ZONE CONNECTING BLOCK

The Model ZC21 is a device that provides independent infrared remote control of two audio/video systems from two zones. One emitter port is provided for each zone, plus one common port so that certain components can be controlled from both zones. The ZC21 is a simplified unit, intended for use when only two zones are needed. When more zones are required, use the Xantech models 795-20 and 796-20 multi-zone controllers and expanders.

### SPECIFICATIONS

- Power requirements: 12 volts DC. Use 781RG or 782-00 Power Supplies.
- 2.1 mm coaxial power jack.
- Inputs: Two 4-screw removable connectors to interface with all 3-lead IR receivers. (See Caution Note near **Fig. 4**)
- Outputs: 2 zone emitter ports and 1 common emitter port (3.5mm miniature phone jacks).
- Can be used with a 789-44 Connecting Block or a 791-44 Amplified Connecting Block for COMMON emitter expansion.
- Uses 282, 283, 284 and 286 series emitters.
- Dimensions: 2-15/16" W x 1-3/4" D x 13/16" H

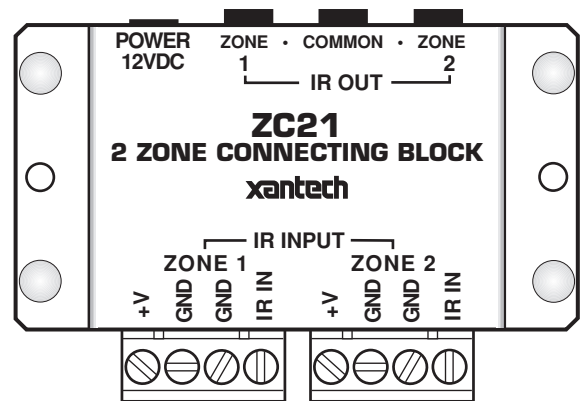

Fig. 1 Model ZC21 2-Zone Connecting Block

### INSTALLATION

**Fig. 2** shows a typical 2-zone installation with a total of four remote rooms. A variety of Xantech IR Receivers are shown, two in each zone. Even more may be wired in parallel, in the same manner as shown, up to a maximum of twelve. More than twelve is not recommended because IR noise picked up by the many IR receivers may cause erratic operation and reduce remote control range.

730-00 Smart Pads may also be used, by themselves or together with the IR receivers. When you do this however, the higher current requirements of the keypads must be taken into consideration as follows:

1. Each 730 Smart Pad draws 70 mA and the Smart Pad<sub>2 or 3</sub> draws 85 mA.
2. Most IR receivers draw 2 mA without signal and 10 mA with signal (check specs. on actual model).
3. The maximum current for proper operation from the 781RG Power Supply is 200 milliamps.
4. The maximum current for proper operation from the 782-00 Power Supply is 1000 milliamps.
5. When using combinations of keypads and receivers, keep below the maximum current ratings of the power supplies as noted above.

For example, two Smart Pad<sub>2 or 3</sub>s and 10 IR receivers could be used with one 781RG Power Supply. 12 Smart Pad<sub>2</sub>'s and 16 IR receivers could be used with one 782-00 Power Supply.

**NOTE:** To avoid current "hogging", **never** connect regulated supplies, such as the 782-00, in parallel!

**NOTE:** For clarity, connections to the 3-conductor cables in this illustration are shown in "daisy chain" fashion. It is recommended that 3-conductor "home-runs" be pulled from each room to the ZC21 Connecting Block in the main room. This maintains higher power supply voltage to each IR receiver (and keypads, if used) for best operation.

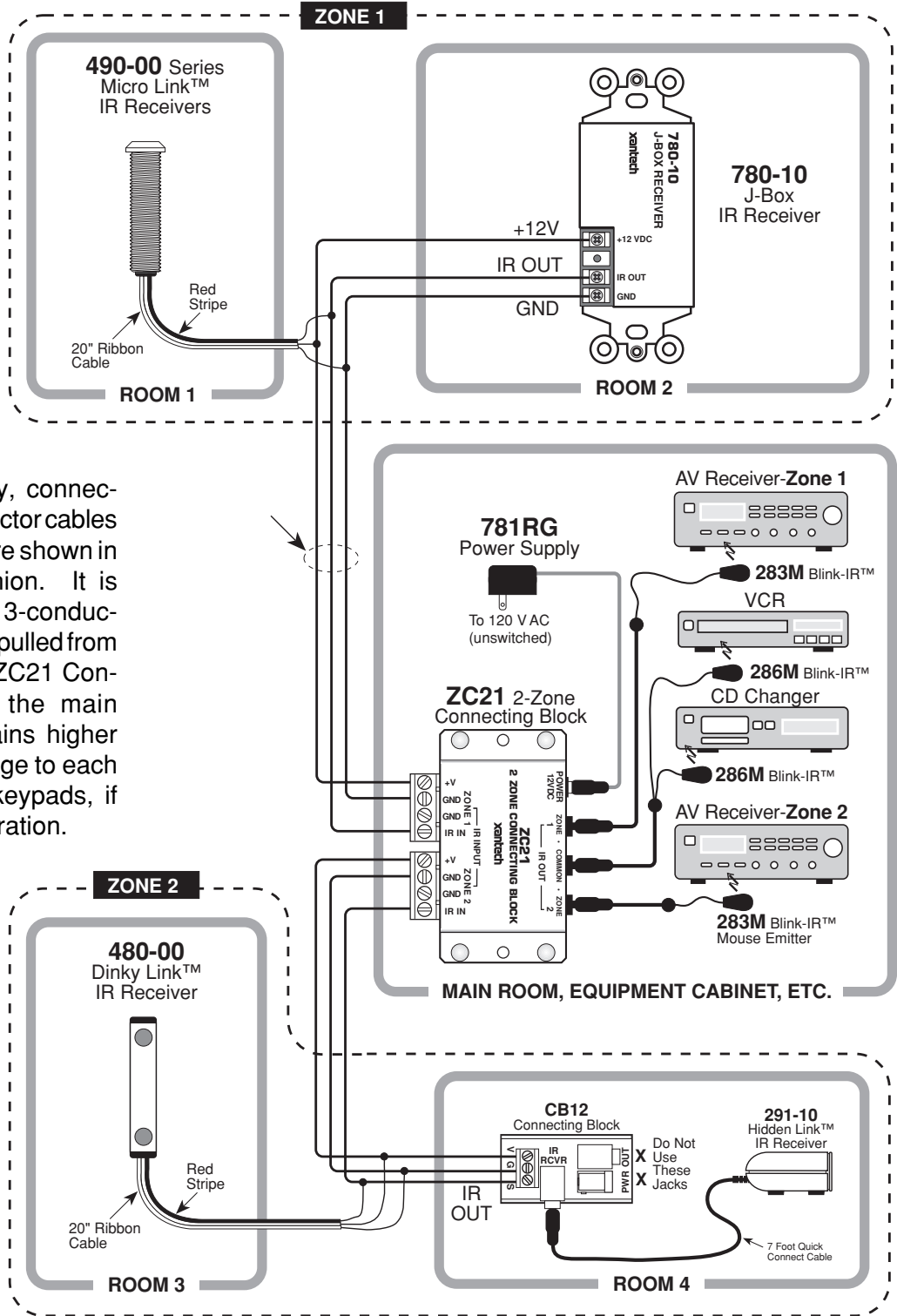

Fig. 2 A typical 2-Zone Installation

**CAUTIONS:**

1. Do not use unregulated 12V power supply adapters from other manufacturers. These may deliver excessive voltage to the IR receivers and cause them to “latch-up”. When this occurs, the “talkback” LEDs and 283 Blink IRs (if used) will stay on continuously!
2. Because the ZONE and COMMON jacks on the ZC21 are connected in series, **you must have an emitter(s), a connecting block (with emitters), or other Xantech IR controlled device plugged into the COMMON jack for the zone emitters to operate!** This is true for the ZONE OUTPUT jacks as well. If you have a problem, troubleshoot the system using the XantechTest-IR™

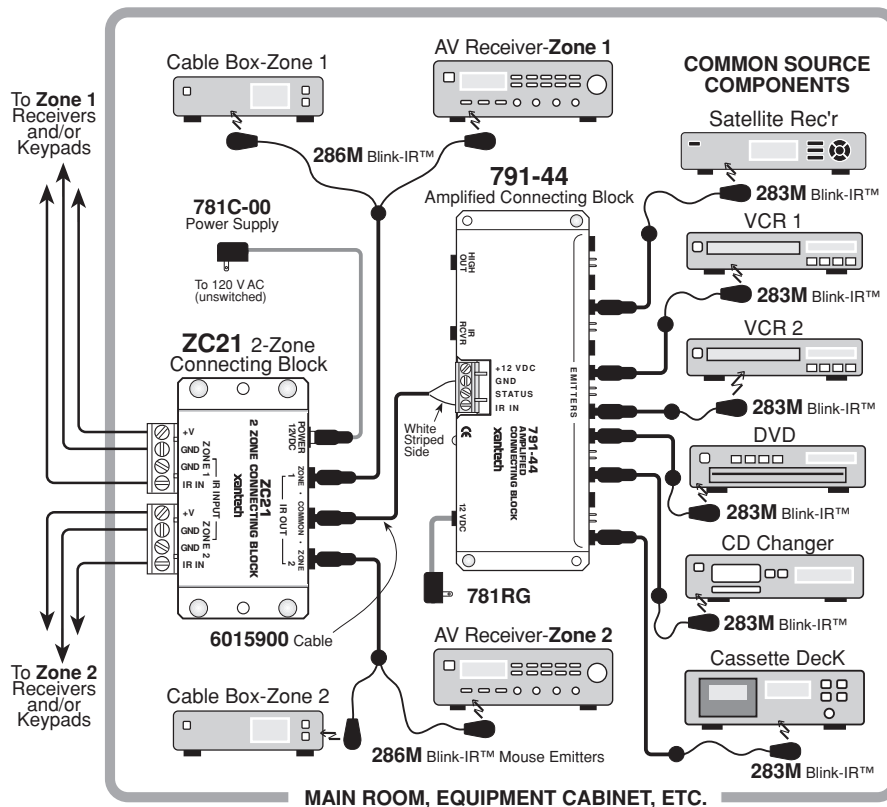

Fig. 3 Using a 789-44 Connecting Block for Emitter Expansion

**EMITTER EXPANSION**

Fig. 2 shows 286M Dual Blink IR™ emitters connected to the single common emitter port on the ZC21 for the common operation of 2 source components. If you need to control more than two, a 791-44 Amplified Connecting Block may be used. Fig. 3 illustrates a 791-44 driving six emitters for control of six common components. Up to ten single or 10 dual emitters may be driven directly from the 791-44. Expansion beyond ten can also be accomplished by plugging a 790-00 Connecting Block into the HIGH OUT jack of the 791-44.

**CAUTIONS:**

1. Because the ZONE and COMMON jacks on the ZC21 are connected in series, **you must have an emitter(s), a connecting block (with emitters), or other Xantech IR controlled device plugged into the COMMON jack for the zone emitters to operate!** This is true for the ZONE OUTPUT jacks as well. If you have a problem, troubleshoot the system using the XantechTest-IR™.

2. Using a 789-44 Connecting Block at the COMMON or ZONE jacks for emitter expansion, is not recommended. The 789-44 is an un-amplified block and, as such, may not pass enough energy to the connected emitters to reliably operate the controlled equipment.
3. When using long lengths (>50 feet) of inter-room shielded cable, it may be necessary to connect a 470 Ohm 1/8 Watt resistor between Input (IR) and GND at each of the ZONE IR input terminals. Refer to **Fig. 4**.

The resistor discharges the cable capacitance more quickly, allowing IR codes of high bit rates to pass without data loss.

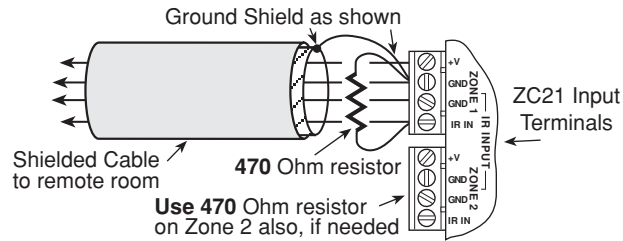

**Fig. 4** 470 Ohm Capacitance Discharge Resistor