

## AC Dual Power Module with Surge Protection

### APPLICATION

This AC Dual Power Module with surge suppression provides power to distribution modules used inside the Structured Media® Center enclosure.

The power module features two 15 Amp duplex receptacles equipped with LEDs and audible alarm that notify the user if surge protection is lost. This device is housed in a white powder-coated steel enclosure that drops in the knock-out panel in the bottom of the Structured Media Center enclosure. It provides power to the active devices installed in the enclosure including routers, switches, modems, audio distribution modules, and security modules.

### SPECIFICATION

The AC Power Module shall be compliant with UL 1449, UL 1863, and be CSA certified. The module shall have an audible alarm which signals an excessive power surge and that the unit is now operating unprotected against further surges. It shall have two receptacles rated at 15 Amps and 125VAC, and include EMI/RFI filtering.

### DESIGN CONSIDERATIONS

- In excessive power surges, a built-in audible alarm sounds to warn the user that power is now unprotected
- Safety clips protect outlets against dust, dirt, and debris
- Two cable knock-outs on bottom for power service connections
- Incorporates two 15 Amp outlets

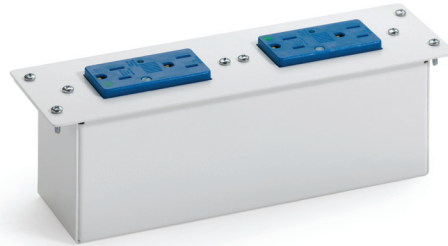

### STANDARDS COMPLIANCE

Meets or exceeds all applicable standards: UL 1449 SPD, and/or 1863 Communications Circuits. CSA certified.

### PHYSICAL SPECIFICATIONS

Dimensions: 10" (H) x 2.8" (W) x 2.3" (D)  
Input: 125VAC, 2 receptacles @ 15 Amps  
Filter: EMI/RFI filtering

### COUNTRY OF ORIGIN

Assembled in Mexico

### WARRANTY INFORMATION

For a copy of Leviton product warranties, visit [Leviton.com](http://Leviton.com)

**ELECTRONIC FILES**

For CAD files, typical specs, or technical drawings (.DXF, .DWG, Visio), visit [www.leviton.com](http://www.leviton.com).

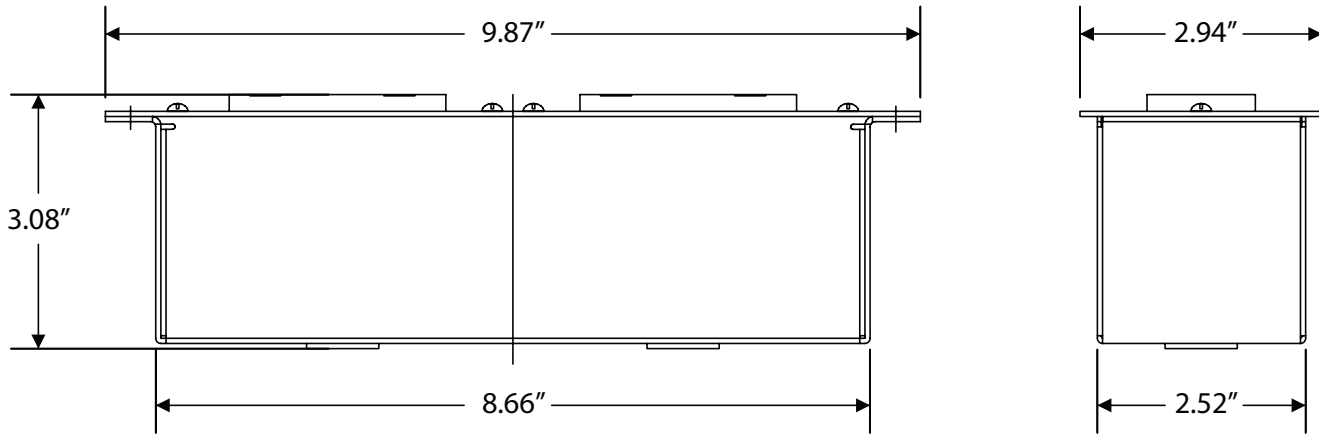

47605-ODP

**PART NUMBERS**

Description	Part Numbers
AC Dual Power Module with Surge Protection	47605-ODP

