

# Switch with Wi-Fi Technology

decora smart™



## APPLICATION

Control connected loads and lights from anywhere using Wi-Fi, an internet connection and the free My Leviton app; that is all you need, no hub required. Simplify control of the residence - schedule lights and connected loads to turn on/off at specific times or based on sunrise/sunset, easily group smart devices into rooms, and create scenes to activate multiple lights at once.

Integrate with IFTTT, utilize auto-shutoff feature as a countdown timer in closets, hallways and bathrooms; plus engage home vs. away to enact randomization of lighting control, providing a lived-in appearance. Supports LED and CFL technologies up to 600 Watts, incandescent lighting loads up to 1800 Watts, along with support for Fluorescent, Resistive, and Motor loads.

## AMAZON ALEXA VOICE CONTROL

Compatible with all products that support Amazon Alexa providing voice control of the load: "Alexa, turn on living room lights". Alexa devices (including Echo, Dot, and Tap) sold separately.

## GOOGLE ASSISTANT VOICE CONTROL

"Ok Google, turn [My Leviton device name] On". Works with the Google Assistant. Google Home is a voice enabled speaker powered by the Google Assistant. Easily control smart devices around the home. (Google Assistant devices sold separately).

## AESTHETICS

Switches leverage the popular Decora form factor and styling, along with compatible accessories including three-way devices, color change kits, and wallplates. The switches feature true rocker action, pressing the top to turn on and the bottom to turn off. To meet any decor, color change kits are available in white, ivory, light almond, gray, black, and brown. For the most professional and cleanest installation, pair the device with an optional Leviton screwless wallplate.

## BENEFITS

- Control your lights from anywhere using the free My Leviton app for iOS and Android, no hub required.
- Amazon Alexa products provide voice control: "Alexa, turn on living room lights". (Echo, Tap, and Dot sold separately).
- Works with Google Assistant including Google Home for voice control. "Ok Google, turn [Google room name] On"
- Integrate with IFTTT for additional third-party functionality
- Simplify control of your home - schedule lights and connected loads to turn on/off at specific times or based on sunrise/sunset, easily group your smart devices into rooms, and create scenes to activate multiple lights at once.

## FEATURES

- White and Light Almond color faces included
- Rated for CFL and LED loads up to 600W
- Rated for incandescent loads up to 1800W
- Multi-location (3-way) switching is achieved using DD0SR-1 Coordinating Remote (no LED indicator) or DD0SR-DLZ Matching Remote (with LED indicator).

### Leviton Manufacturing Co., Inc. Global Headquarters

201 N. Service Rd. Melville, NY 11747-3138 Tech Line: 1-800-824-3005 Fax: 1-800-832-9538

### Leviton Manufacturing Co., Inc. Energy Management, Controls and Automation.

4330 Michoud Blvd., New Orleans, LA, 70129 Tel: 1-504-736-9810 Fax: 1-504-253-2954

Visit our Website at: [www.leviton.com/decorasmart](http://www.leviton.com/decorasmart)

©2017 Leviton Manufacturing Co., Inc. All rights reserved. Subject to change without notice.

**SINGLE POLE WIRING DIAGRAM**

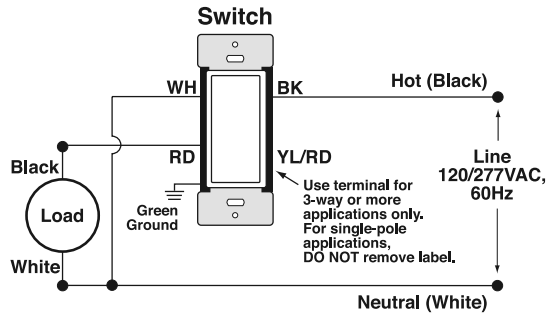

**THREE-WAY WIRING DIAGRAM**

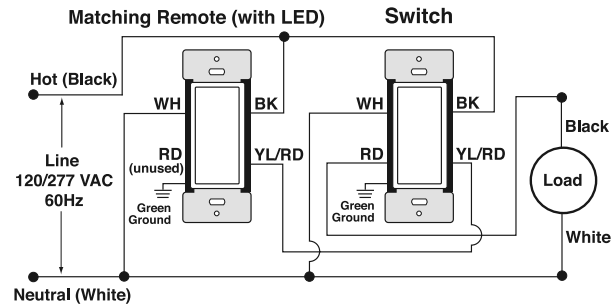

**ORDERING INFORMATION**

DESCRIPTION	CAT. NO.
15A Switch with Wi-Fi Technology	DW15S-1BZ
Coordinating Switch Remote	DD0SR-1
Matching Switch Remote	DD0SR-DLZ

**AGENCY STANDARDS AND COMPLIANCE**

- Complies with UL 917
- CSA Certified (File #003413)
- NOM-ANCE Certified
- Wi-Fi CERTIFIED™
- Complies with FCC Part 15, Class B

**RATINGS**

- Incandescent - 1800W - 120VAC, 60Hz
- LED/CFL - 5A, 600W - 120VAC, 60Hz
- Fluorescent - 15A - 120VAC, 60Hz;  
8A - 277VAC, 60Hz
- Resistive - 15A - 120VAC, 60Hz
- Motor - 1/2 HP - 120VAC, 60Hz

**WARRANTY INFORMATION**

Five-Year Limited Warranty

**Leviton Manufacturing Co., Inc. Global Headquarters**

201 N. Service Rd. Melville, NY 11747-3138 Tech Line: 1-800-824-3005 Fax: 1-800-832-9538

**Leviton Manufacturing Co., Inc. Energy Management, Controls and Automation.**

4330 Michoud Blvd., New Orleans, LA, 70129 Tel: 1-504-736-9810 Fax: 1-504-253-2954

Visit our Website at: [www.leviton.com/decorasmart](http://www.leviton.com/decorasmart)

©2017 Leviton Manufacturing Co., Inc. All rights reserved. Subject to change without notice.

SAT-10113  
REV JUL 2017