

QUICKSTART "BASIC" HARDWIRE TRACKER EXPANSION BOARD TO RELAY 2/WIEGAND 2 GUIDELINES

For COMPLETE installation instructions, please refer to the HARDWired Installation/Owner's manual P/N 2358-065.



120 Glasgow Avenue
Inglewood, California 90301
U.S.A.

Tracker Expansion Board Enclosure Options

Single Board Enclosure with Built-In Card Reader and Lighting
DK Prox Reader - P/N 1815-333
HID Reader - P/N 1815-392
AWID Reader - P/N 1815-292

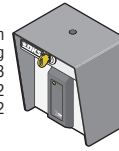

Single Board Enclosure
P/N 2351-080

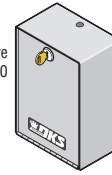

Quad Board Enclosure
P/N 2351-081

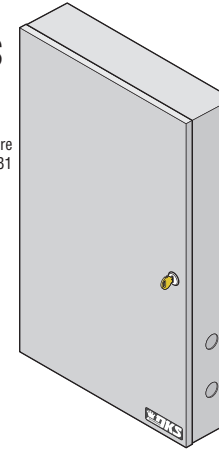

Tracker Expansion Board Notes:

All tracker expansion boards can be wired with desired options for their access points like shown on tracker expansion board address 3.

Communication line will continue for each board like shown on tracker expansion board address 4.

Board addresses **MUST** start at 3 and continue thru board address 10 (up to 12 boards using Zone Addresses) if required.

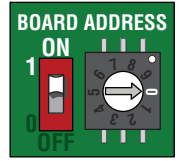

Board Address 10 Setting

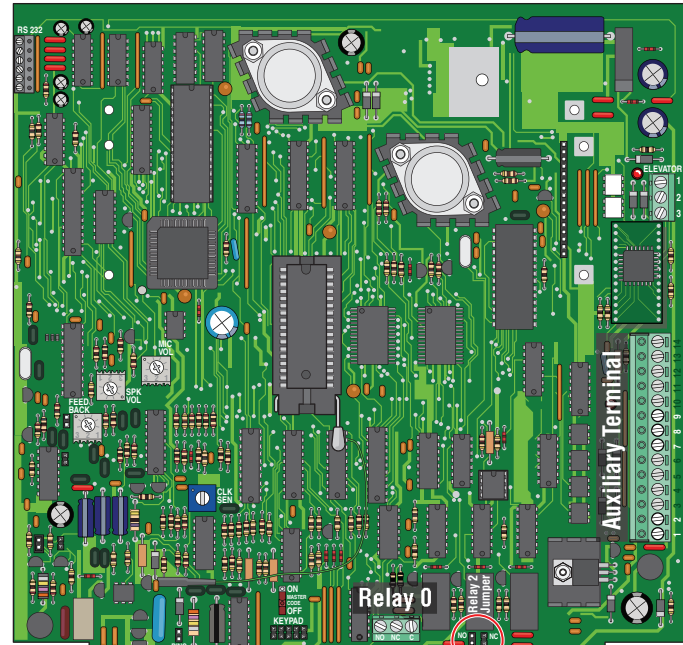

Access Control System Board

Auxiliary Terminal
Black #9-Com
White #8-Data 1
Green #7-Data 0

Communication 2

Tracker expansion boards connected to Wiegand 2 will activate Relay 2 in the access control system.

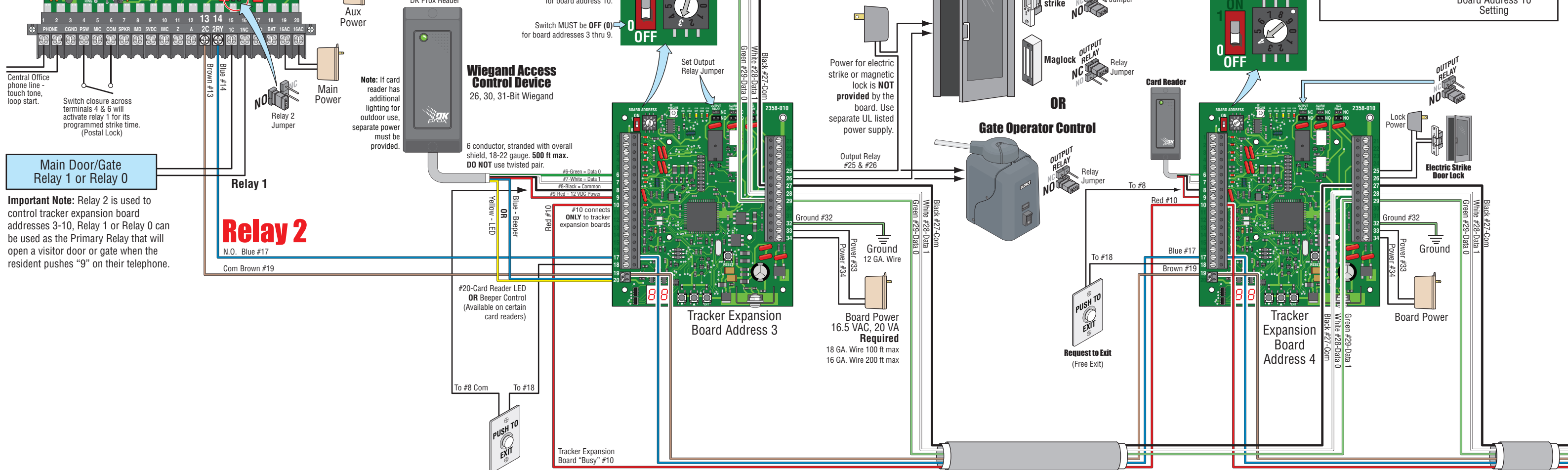

Main Door/Gate Relay 1 or Relay 0

Important Note: Relay 2 is used to control tracker expansion board addresses 3-10, Relay 1 or Relay 0 can be used as the Primary Relay that will open a visitor door or gate when the resident pushes "9" on their telephone.

Relay 2

N.O. Blue #17
Com Brown #19

Note: If card reader has additional lighting for outdoor use, separate power must be provided.

Typical BASIC Tracker Expansion Board Wiring Options for Access Point

NO "optional" tracker features or battery back-up wiring shown, see manual for details.

Power for electric strike or magnetic lock is **NOT** provided by the board. Use separate UL listed power supply.

Board Power
16.5 VAC, 20 VA Required
18 GA. Wire 100 ft max
16 GA. Wire 200 ft max

Use 6 conductor stranded with overall shield. 18 - 22 gauge.
ONLY use 18 gauge when wiring more than 8 boards.
DO NOT connect shield to 2358-010 board common.
DO NOT use twisted pair.

Communication Line

Up to 12 tracker expansion boards can be HARDwired to relay 2/wiegand 2 at the access control system.

IMPORTANT: The maximum distance for a tracker expansion board HARDwire run is 4000 feet TOTAL (1 to 12 boards can be in a HARDwire run). The farthest board can be NO more than 2000 feet away from the access control system. See manual for multiple tracker expansion boards layout limitations.

QUICKSTART PROGRAMMING OPTIONS ON EACH HARDWIRED TRACKER EXPANSION BOARD GUIDELINES



120 Glasgow Avenue
Inglewood, California 90301
U.S.A.

For COMPLETE programming instructions, please refer to the HARDWIRED Installation/Owner's manual P/N 2358-065.

Programming Options on EACH Tracker Expansion Board

Rev-E 1-13-14

Program Step	Description	Options	Selection Number	Function	Factory Default
1	Door Strike Timer	00 - 99	00	Sets Strike Time for output relay (term 25 & 26) 0.25 second strike time	01 - 1 second
			01 - 99	Strike time in 1-second increments	
2	Free Exit Timer, Strike Time	00 - 99	00	Set Strike Time for RX (Request to Exit) of output relay (input at term 18) 0.25 second Egress Strike time	01 - 1 second
			01 - 99	Egress Strike time in 1-second increments	
3	Door Ajar Timer	00 - 99	00	Timer starts when valid access has been granted. 1 second Door Ajar Timer	12 - 60 secs
			01 - 99	Timer set in 5-second increments: 01 = 5 seconds, 10 = 50 seconds	
4	Aux Relay Timer	00 - 99	00	Timer setting for Aux Relay activation in 5-second increments 1 second Door Ajar Timer	12 - 60 secs
			01 - 99	Timer set in 5-second increments: 01 = 5 seconds, 10 = 50 seconds	
5	Free Exit Timer, Aux Relay	00 - 99	00	Set Strike Time for RX (Request to Exit) of Aux relay (ONLY available if Dual Door Mode step 12 is ON) 0.25 second Egress Strike time	01 - 1 second
			01 - 99	Egress Strike time in 1-second increments	
6	Free Exit, No Strike	0 or 1	0	Set RX (Request to Exit) function. Activate Output Relay or do not Activate Output Relay Do Not Activate Output Relay or Reader Beeper/LED when RX input is received	1 - Activate
			1	Activate Output Relay and Reader Beeper/LED for Free Exit Strike Time when RX received	
7	Not Used				
8	Door Contact Switch Logic	0 or 1	0	Sets type of Door Switch contacts N.O. contact from door switch with Door Closed (Circuit Open - CO)	0 - N.O.
			1	N.C. contact from door switch with Door Closed (Circuit Close - CC)	
9	Auto Relock	0 or 1	0	Turns on Auto Relock function (not available if Dual Door Mode, step 12 is ON) Output Relay is activated for Strike Time	0 - Disabled
			1	Door Contact Switch required. If door returns to closed position during Strike Time door will "relock" after 1 second, even if strike time has not expired.	
10	Beeper / LED Hold Open	0 or 1	0	Sets how BEEPER or LED will function during Hold Open When Hold Open occurs, Beeper or LED is active only during Strike Timer	0
			1	When Hold Open occurs, Beeper or LED will remain active during Hold Open	
11	Hold Open or Hold Egress functions	0 or 1	0	Sets how Aux & Alarm Relay responds during Hold Open or Hold Egress situation No Aux Relay functions. Alarm will be in "Reset". If Alarm Relay is set for "integral" mode, Alarm relay will not activate. If Alarm Relay set for "Bypass" mode, Alarm Relay will activate for Hold Open period or Extended Egress Hold.	0 - No relay functions
			1	Aux Relay will function for all settings. If Alarm Relay is set for "integral" mode, Alarm relay will not activate. If Alarm Relay set for "Bypass" mode, Alarm Relay will activate for Hold Open period or Extended Egress Hold.	
12	Dual Door Mode	0 or 1	0	Sets Tracker to function as 2 Access Points (2 tracker addresses) Disabled, Tracker functions as single access point	0 - Disabled
			1	Dual Mode: Tracker functions as set board address and next sequential address Card Read will be sent to controller as set board address, access is granted or denied Card then sent as set address +1, access granted or denied. Aux Relay becomes 2nd output relay. All other Aux Relay functions disabled. Door Contact switch becomes RX (Request to Exit) for 2nd address.	
13	Not Used				
14	Not Used				
15	Aux Relay Functions	0 - 12	0	Sets function for Aux Relay Aux Relay Disabled	0 - Disabled
			1	No Door Ajar Timer: Requires Door Contact Switch. Aux Relay activates when Door Not Closed.	
			2	No Door Ajar Timer, Pulse: Requires Door Contact Switch. Aux Relay "pulses" when Door Not Closed.	
			3	Door Ajar Timer: Requires Door Contact Switch. When door opens, start Door Ajar Timer. When timer expires Aux Relay activates for Aux Relay timer or until door closes, whichever occurs first.	
			4	Door Ajar Timer, Pulse: Requires Door Contact Switch. When door opens, start Door Ajar Timer. When timer expires Aux Relay Pulses for Aux Relay timer or until door closes, whichever occurs first.	
			5	Door Ajar, Pulse warning the ON: Requires Door Contact Switch. When door opens, Pulse Aux Relay and start Door Ajar Timer. When timer expires Aux Relay ON for Aux Relay timer or until door closes, whichever occurs first.	
			6	Door opens for any reason, Start Door Ajar timer and pulse Aux Relay. When Door Ajar timer expires, start Aux Timer and continue Pulsing Aux Relay. When Door Closes or both timers expire, turn off Aux Relay	
			7	Aux Relay as 2nd Alarm Relay: Aux Relay will mirror Alarm Relay functions.	
			8	Aux Relay as 2nd Alarm Relay, PULSE: Aux relay will Pulse during any Alarm Relay activation.	
			9	Good Card: Aux Relay will activate for Aux Relay timer for any Access Granted Card	
			10	Any Card: Aux Relay will activate for Aux Relay Timer when any card has been presented.	
			11	Bad Card: Aux Relay will activate for Aux Relay timer when a card has been denied	
12	Warn before Hold Open or Release of Hold Open: Aux relay will activate for Aux Relay timer when scheduled Hold Open begins or ends. Output Relay will be delayed until Aux Timer expires. DO NOT set Aux Timer above 60 seconds in this mode.				
16	Alarm Relay Functions	0 - 4	0	Sets function for Alarm Relay Aux Relay Disabled	0 - Disabled
			1	Bypass Mode: Alarm Relay provides "Bypass" to Alarm Door Switch. With proper door input (access or egress) activate Alarm Relay, start Strike timer and Door Ajar timer. When Door Ajar timer expires, deactivate Alarm Relay. If second Door Contact Switch is provided, generate transaction for Door Ajar and Door Closed following Door Forced condition. Also generate transaction for Door Forced condition.	
			2	Integral Mode, Door Ajar Timer: Door Contact Switch connected to Tracker, Alarm Relay provides connection directly to Alarm System. When door is opened for any reason, start Door Ajar timer. When Door Ajar timer expires and Door is still OPEN, activate Alarm Relay. Reset when door closes. Send Door Ajar and Door Close transactions.	
			3	Integral Mode, Proper and Forced condition: Door Contact Switch connected to Tracker, Alarm Relay provides connection directly to Alarm System. With proper door input (access or egress) start Strike timer and Door Ajar timer. When Door Ajar timer expires and Door is still OPEN, activate Alarm Relay. Reset when door closes. If door is opened without proper condition, activate alarm relay. When door closes deactivate Alarm Relay. Send Door Ajar, Door Close and Door Forced transactions.	
4	Gate Alarm Function: Alarm Relay will activate for 1 second when tracker board receives a "Gate Forced" or "Gate Obstructed" transaction from the operator control board.				
17	Not Used				
18	Not Used				
19	Reset to Factory Defaults	5	5	Sets all parameters to Factory Default	
20	View RF POT Setting	Adjustable Setting		Sets maximum amount of allowable signal strength loss	
21	View RF Signal Loss	Displays on LED		Displays current signal loss between Base and Tracker.	
22	Card Code Forwarding	0 or 1	0	Sets Wireless Tracker to act as Repeater ONLY USE AS DIRECTED BY DOOR KING TECH SUPPORT 0=Repeater Mode OFF 1=Repeater Mode ON	0 - Off
			1		

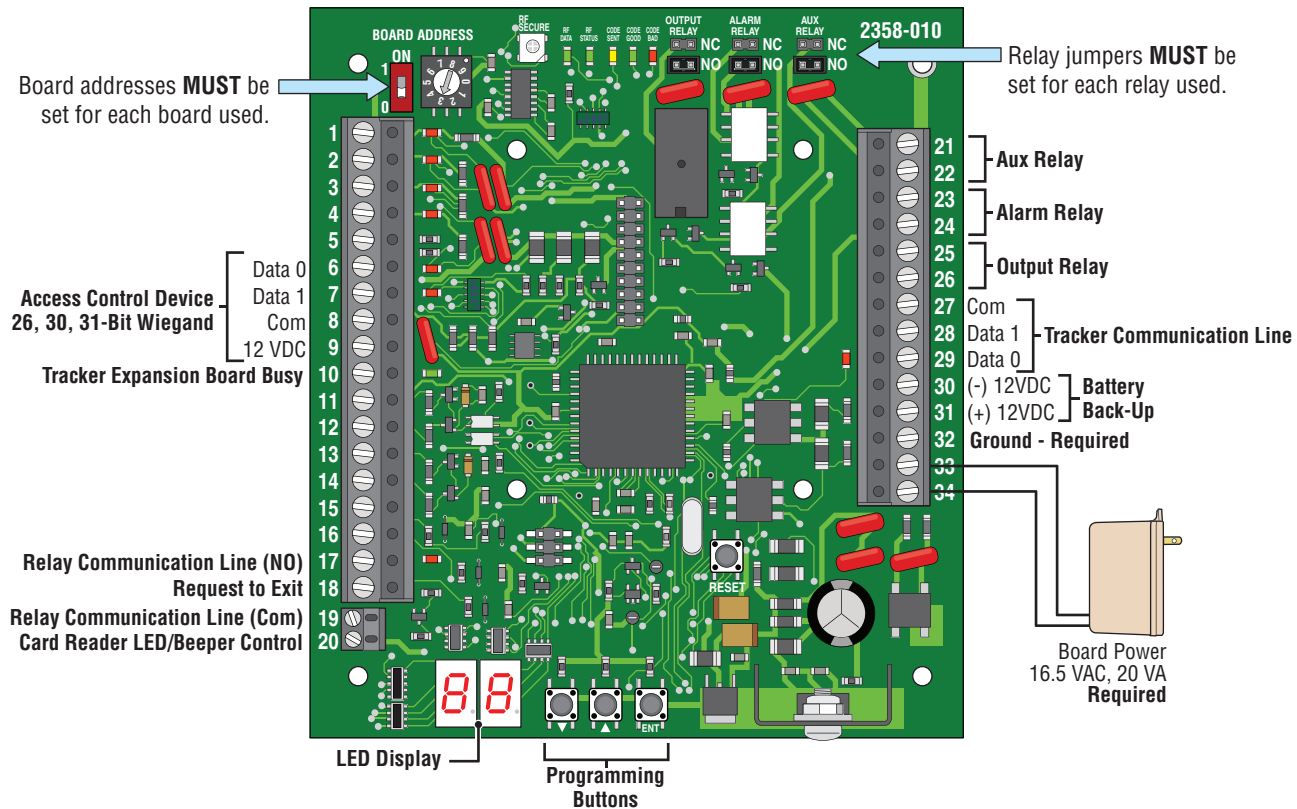

Basic Programming Sequence on EACH Tracker Expansion Board

Follow these basic steps to perform desired programming. See programming options table for PROGRAM STEPS.

1. Press ▼▲ arrow buttons or ENT button to ACTIVATE LED display.
2. Press ▼▲ arrow buttons again to CHOOSE desired PROGRAM STEP.
3. Press ENT button to ENTER desired PROGRAM STEP.
(LED display number will blink after ENT button has been pressed).
4. Press ▼▲ arrow buttons to choose SELECTION NUMBER for desired function of program step.
5. Press ENT button to program SELECTION NUMBER for desired function of program step.
(Function has now been programmed into board).
6. Press ENT button again to exit programming OR after 10 seconds, board will automatically exit programming.

Note: Repeat these steps for all other desired programming functions.

Each tracker expansion board will have to be INDIVIDUALLY programmed with desired functions.

After all tracker expansion boards have been programmed.....

Manage the Complete Access Control System from Your PC

Refer to the DKS Remote Account Manager Software to program and manage the complete system.



Your PC connected to the access control system. Either IM Server OR TCP/IP OR RS-232 OR Modem to Modem Connection. See PC Programmable Telephone Entry and Access Control Systems Installation/Owner's manual for more information about connection options.

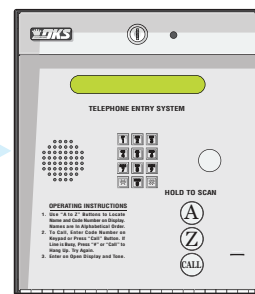

IMPORTANT Display Decimal Point Note

