



**PRT-PSU-DIN-8A**

# Protege DIN Rail 8A Intelligent Power Supply

Installation Manual



The specifications and descriptions of products and services contained in this document were correct at the time of printing. Integrated Control Technology Limited reserves the right to change specifications or withdraw products without notice. No part of this document may be reproduced, photocopied, or transmitted in any form or by any means (electronic or mechanical), for any purpose, without the express written permission of Integrated Control Technology Limited. Designed and manufactured by Integrated Control Technology Limited, Protege® and the Protege® Logo are registered trademarks of Integrated Control Technology Limited. All other brand or product names are trademarks or registered trademarks of their respective holders.

Copyright © Integrated Control Technology Limited 2003-2022. All rights reserved.

Last Published: 06-Jul-22 03:00 PM

# Contents

<b>Introduction</b>	<b>5</b>
<b>Installation Requirements</b>	<b>6</b>
<b>Grounding Requirements</b>	<b>7</b>
Safety Grounding	7
Earth Ground Connection	7
<b>Mounting</b>	<b>9</b>
Removal	9
Cabinet Tamper Switch	9
Vibration Sensor	10
Connection	10
Modes of Operation	11
Installation Procedure	11
<b>Wiring Diagram</b>	<b>13</b>
<b>Mains Power</b>	<b>14</b>
<b>Backup Battery</b>	<b>15</b>
Connecting The Battery	15
Backup Battery Thresholds	16
<b>Encrypted Module Network</b>	<b>17</b>
Module Wiring	18
End of Line (EOL) Resistors	18
<b>Output Load Connection</b>	<b>19</b>
Output Current Influence on Output Load Operation	20
Core Temperature on Output Load Operation	20
<b>Inputs</b>	<b>21</b>
Trouble Inputs	21
<b>Outputs</b>	<b>22</b>
Online Mode	22
Programmable Outputs	22
Offline Mode	22
AC Fail Status Output	22
Battery Fail Status Output	23
<b>Intelligent Monitoring</b>	<b>24</b>
Monitoring Setup	24
<b>Address Configuration</b>	<b>25</b>

<b>LED Indicators</b>	<b>26</b>
Status Indicator	26
Fault Indicator	26
Power Indicator	26
V1 Output/V2 Output Indicators	26
Battery Indicator	27
Temp Indicator	27
Output Current Indicator	27
<b>Error Code Indication</b>	<b>28</b>
Error Code Display	28
<b>Mechanical Diagram</b>	<b>29</b>
<b>Mechanical Layout</b>	<b>30</b>
<b>Technical Specifications</b>	<b>31</b>
<b>New Zealand and Australia</b>	<b>32</b>
<b>European Standards</b>	<b>33</b>
<b>UK Conformity Assessment Mark</b>	<b>35</b>
<b>FCC Compliance Statements</b>	<b>36</b>
<b>Industry Canada Statement</b>	<b>37</b>
<b>Disclaimer and Warranty</b>	<b>38</b>

# Introduction

---

The Protege DIN Rail 8A Intelligent Power Supply provides 12VDC power suited to powering security, access control or automation devices along with large numbers of Protege network powered modules, and allows for simple and powerful monitoring of supply currents and voltages.

Flexible module network architecture allows large numbers of modules to be connected to the RS-485 module network. Up to 250 modules can be connected to the Protege system in any combination to the network, over a distance of up to 900M (3000ft). Further span can be achieved with the use of a network repeater module.

The current features of the power supply include:

- Industry standard DIN rail mounting
- Online and remote upgradeable firmware
- Secure encrypted RS-485 module communications

# Installation Requirements

---

This equipment is to be installed in accordance with:

- The product installation instructions
- AS/NZS 2201.1 Intruder Alarm Systems
- The Local Authority Having Jurisdiction (AHJ)

# Grounding Requirements

An effectively grounded product is one that is intentionally connected to earth ground through a ground connection or connections of sufficiently low impedance and having sufficient current-carrying capacity to prevent elevated voltages which may result in undue hazard to connected equipment or to persons.

Grounding of the Protege system is done for three basic reasons:

1. Safety
2. Component protection
3. Noise reduction

## Safety Grounding

The object of safety grounding is to ensure that all metalwork is at the same ground (or earth) potential. Impedance between the Protege system and the building scheme ground must conform to the requirements of national and local industrial safety regulations or electrical codes. These will vary based on country, type of distribution system and other factors. The integrity of all ground connections should be checked periodically.

General safety dictates that all metal parts are connected to earth with separate copper wire or wires of the appropriate gauge.

## Earth Ground Connection

The DIN rail enclosure and the DIN rail modules must be grounded to a suitable single-point earth ground connection in the installation. A minimum 14AWG solid copper wire (or thicker, in accordance with local authorities) shall be used from the Protege system's earth connection points.

The DIN rail enclosure includes an earth ground single-point link connection via the metallic enclosure. This single-point link is the Protege system's earth ground. All modules that have earth ground connections and that are installed in the same enclosure shall be connected to this single point. A single-point earth ground connection avoids the creation of ground loops in the system and provides a single reference point to earth ground.

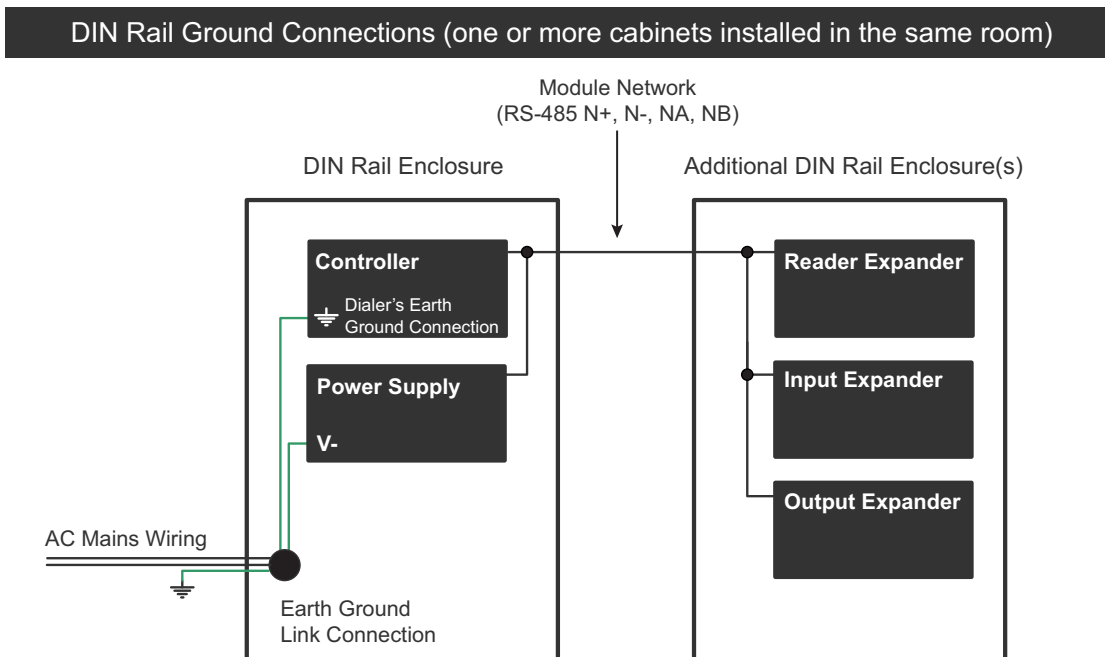

## DIN Rail Ground Connections (multiple cabinets in different rooms, sectors, or buildings)

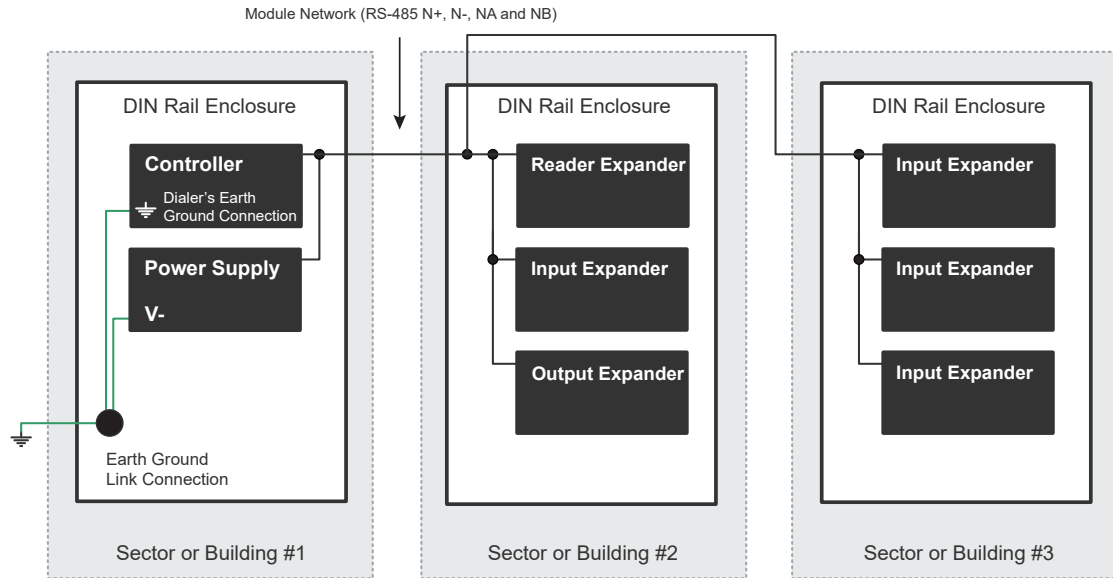

The Dialer's Earth Ground Connection applies to modem model controllers only.

Note that the DIN rail enclosure earth terminal is connected to the power supply V- terminal.

There must be only **one** single earth grounding point per system.



# Mounting

Protege DIN rail modules are designed to mount on standard DIN rail either in dedicated DIN cabinets or on generic DIN rail mounting strip.

When installing a DIN rail module, ensure that there is adequate clearance around all sides of the device and that air flow to the vents of the unit is not restricted. It is recommended that you install the module in a location that will facilitate easy access for wiring. It is also recommended that the module is installed in an electrical room, communication equipment room, secure cabinet, or in an accessible area of the ceiling.

1. Position the DIN rail module with the labeling in the correct orientation.
2. Hook the mounting tabs (opposite the tab clip) under the edge of the DIN rail.
3. Push the DIN rail module against the mount until the tab clips over the rail.

## Removal

A Protege DIN rail module can be removed from the DIN rail mount using the following steps:

1. Insert a flat blade screwdriver into the hole in the module tab clip.
2. Lever the tab outwards and rotate the unit off the DIN rail mount.

## Cabinet Tamper Switch

The enclosure tamper input notifies the monitoring station or remote computer that the enclosure has been opened. If the tamper switch is already mounted in your ICT enclosure, simply cut the cable tie once the enclosure is in place to allow the switch to actuate. Otherwise, mount the tamper switch to the enclosure with the bracket provided.

When the tamper input switch terminals are connected in series with the dedicated tamper input (TP) and V-terminal of the power supply, it will open the trouble input AExxx:01 on the power supply. Alternatively, connect the tamper switch to any other system input designated and programmed as a 24HR tamper alarm input.

**Tamper Input Connection:**

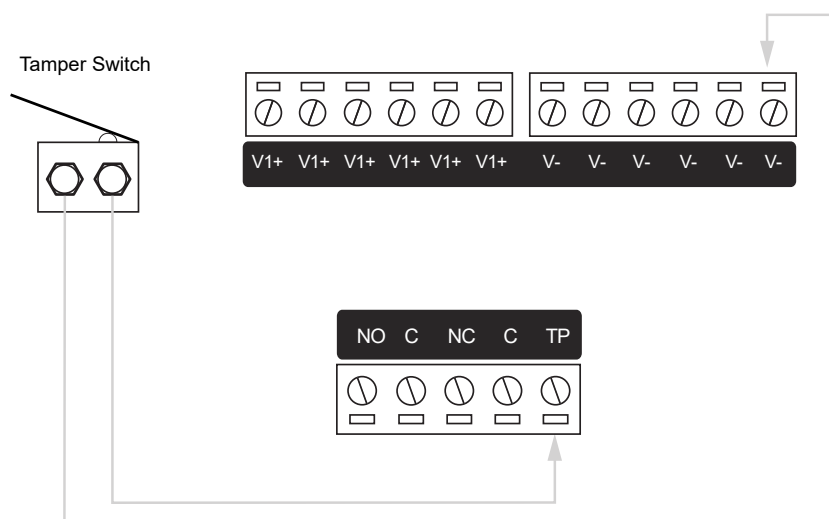

# Vibration Sensor

Protection is provided by a DSC SS-102 Shockgard seismic vibration sensor mounted within the system enclosure.

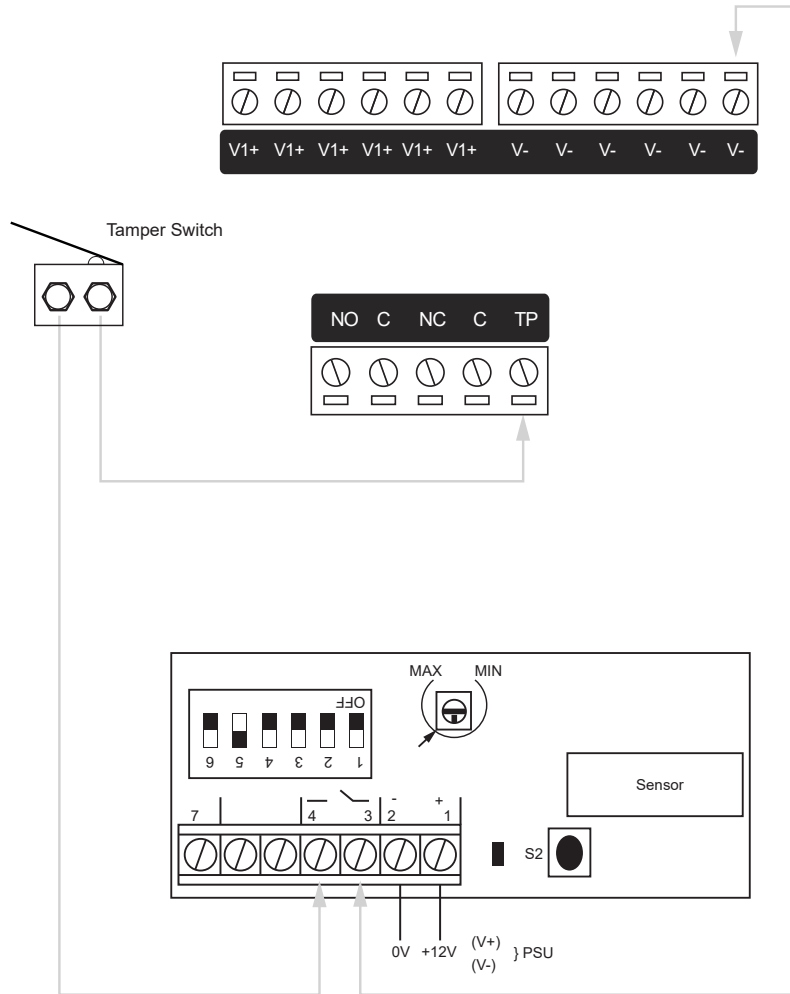

## Connection

- Terminals **1(V+)** and **2(V-)**. 12V power connection, reverse polarity protected.
- Terminals **3 and 4**. N.C. alarm output contacts, with built in 10 ohm resistor in series.

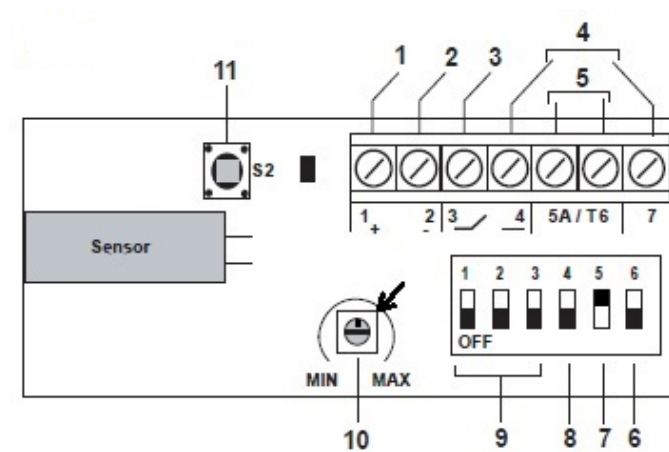

1. 12V (Screw terminal 1).
2. 0V (Screw terminal 2).
3. Alarm circuit. N/C contact. (Screw terminals 3&4).
4. Latch terminal (12V SET + SW +). Not used.
5. Anti-tamper. Terminals not used.
6. Not used. Off.
7. Sensitivity selection level (Low/High). Switch 5 set to on. High selected.
8. Latch reset switch. Not used. Off.
9. Pulse count selection switches. Not used. Off.
10. Sensitivity adjustment potentiometer.

Set pointer marker to point at the corner opposite the MIN marker.

11. Case anti-tamper switch. Not used.

## Modes of Operation

When using the sensor in momentary mode it will be necessary to connect using a 4 core cable.

- The N.C. alarm contacts are non-latching.
- Upon alarm activation the alarm contacts will open circuit momentarily for a minimum time of 1 second before automatically resetting.
- The LED will illuminate when the alarm contacts are open circuit in response to an input signal.
- LED indication: During the sensitivity test procedure indication of the **green** LED denotes alarm and relay operation. Indication of the **red** LED denotes vibration detected (pulse) but insufficient to create alarm conditions.
- Dual stage linear sensitivity: The detector permits the installer a greater threshold of sensitivity adjustment by adjustment of the potentiometer through either a low level or high level adjustment.
- When DIP Switch 5 is in the ON position the sensitivity potentiometer allows adjustment in the high sensitivity area and when in the OFF position allows adjustment in the low sensitivity area.

## Installation Procedure

1. Select the intended position for installation, ideally positioned horizontally in the vertical center of the enclosure, 50mm to the right of the large opening.

Ensure the surface is clean and clear of any irregularities.

2. Remove the sensor cover by unscrewing the single captive screw until the cover can easily be removed from the base.
3. Carefully lift the printed circuit board from the base.
4. Position the base in the mounting position and mark the desired fixing holes (3.1mm drill).
5. If rear cable entry is required, cables should be threaded through the rear of the base.
6. Fix the base in position using M3 pan head machine screws to the captive nuts provided in the enclosure, or with nuts and washers if located in an alternative position.

Take care not to let the screw protrude further than the nut height on the rear of the enclosure.

7. Carefully push the printed circuit board onto the base.
8. Make the electrical connections to the Shockgard SS-102, wired in series with the enclosure tamper switch 24HR monitor.
9. If side cable entry is being used, remove the appropriate knockout from the cover and insert a grommet.

10. Setting up and adjustment:

- With the unit in momentary operation (See Modes of Operation: Dual stage linear sensitivity above), use a terminal screwdriver to turn the sensitivity control fully clockwise to maximum (Position 6).
- Using a suitable implement, bang or tap the protected area, observing the LED response.
- Reduce the sensitivity by a small amount (turn sensitivity control anti-clockwise) and bang or tap the protected area.
- Repeat this process until the unit only just responds to the desired impact.

11. Replace the sensor cover, tighten the fixing screw and check its response to the desired impact.

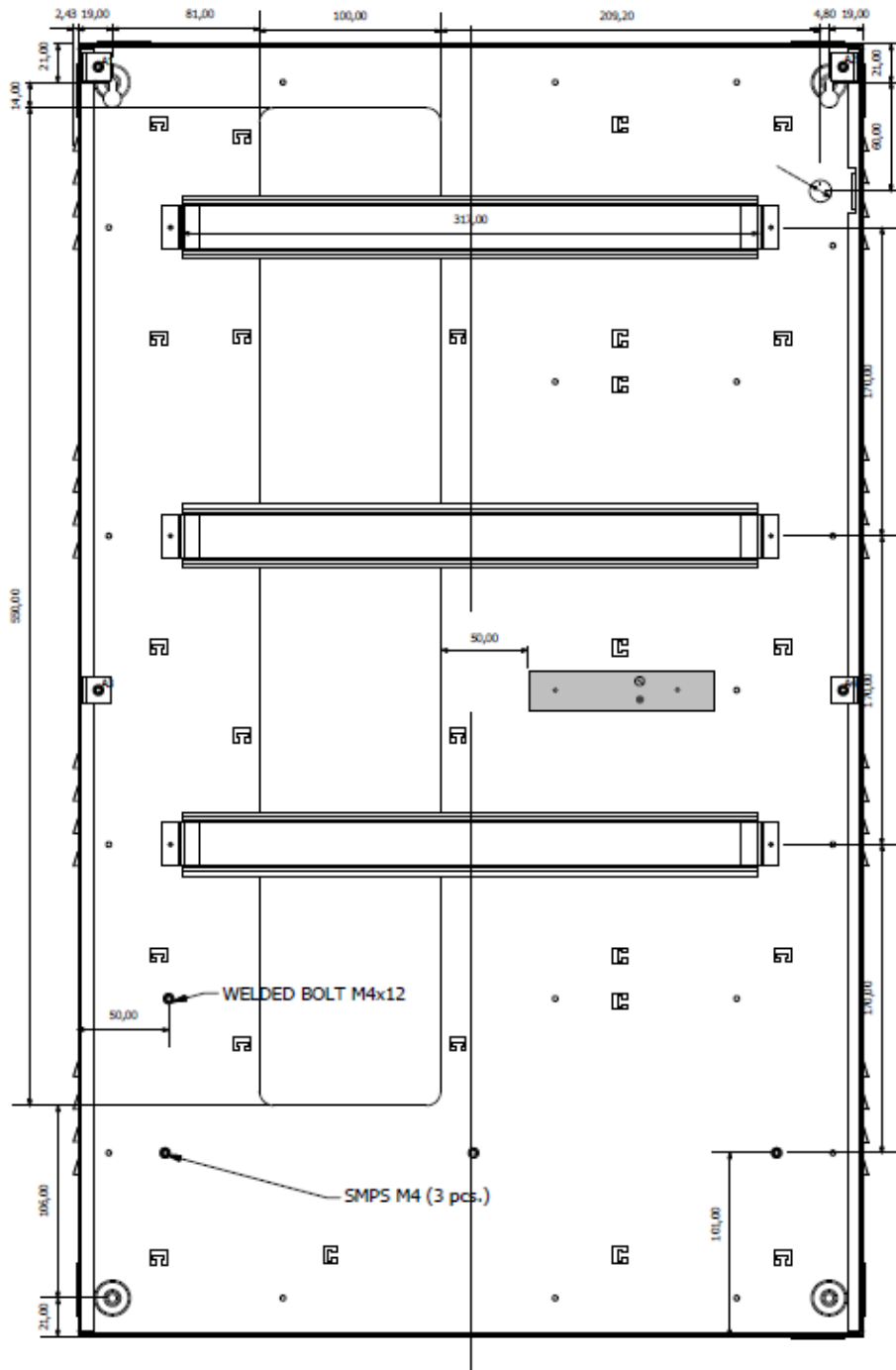

# Wiring Diagram

**CAUTION:** Incorrect wiring may result in damage to the unit.

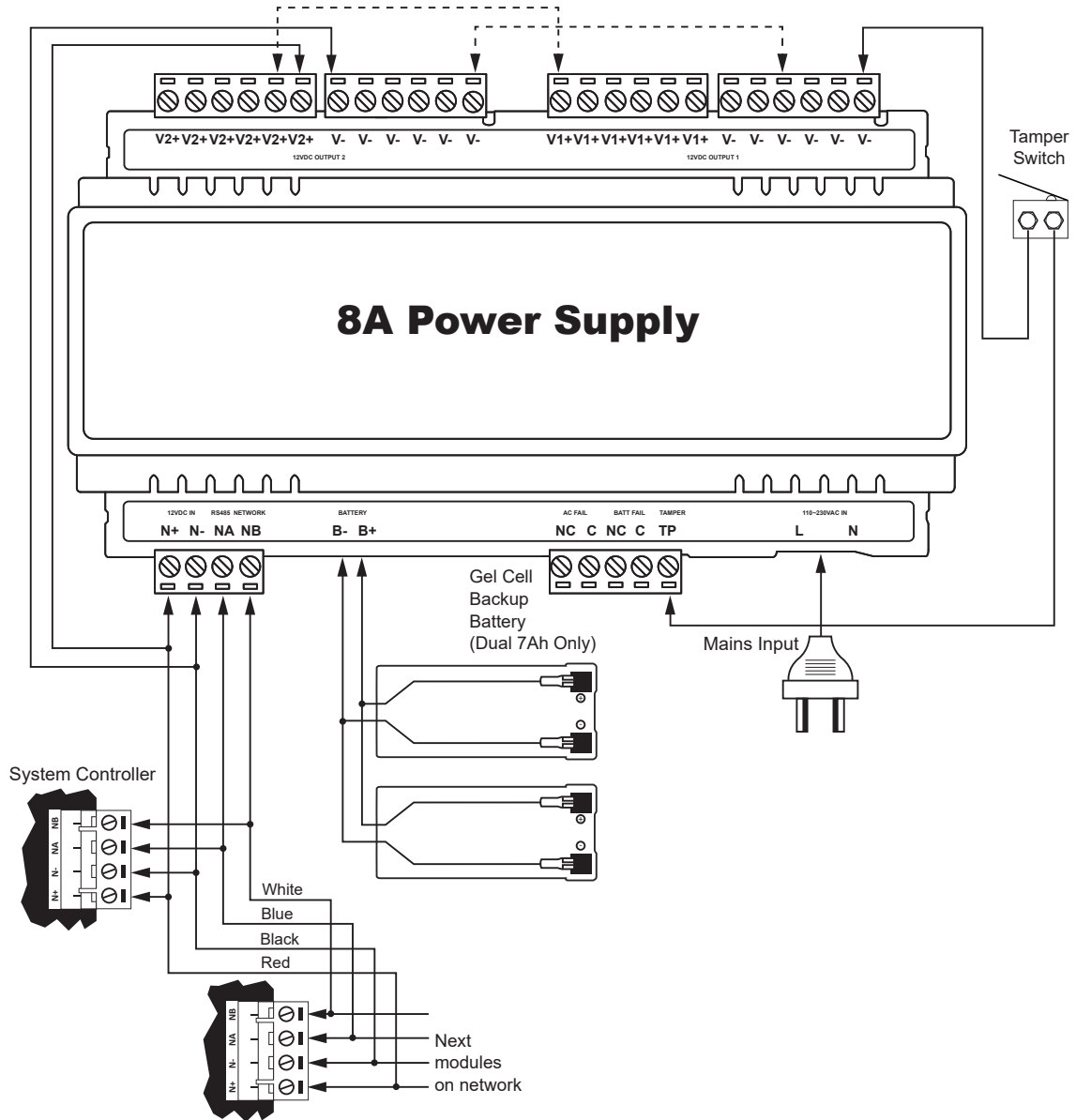

# Mains Power

---

The power supply should be supplied by a dedicated electrical power source rated for a minimum 5 amp load and have a dedicated circuit breaker.

Connect the power supply module to mains input via an appropriate IEC-C7 90 degree cable.

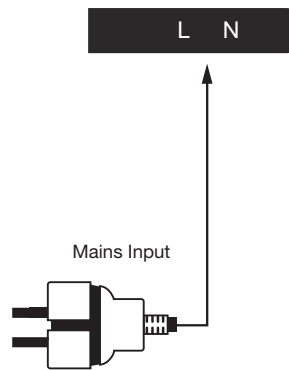

The earth wire shall be routed to the V- terminal on the power supply.

## Warning:

- This installation should be made by qualified service personnel and should conform to all local codes.
- Termination of wiring to the power supply while power is applied or the battery is connected may cause serious damage to the power supply and will **VOID ALL WARRANTIES OR GUARANTEES**. Power the unit only after all wiring, configuration and jumper settings are completed.
- Extra care must be taken when wiring the AC inputs. Improper connection will cause permanent damage to the power supply.

# Backup Battery

A battery backup must be connected to the module network to provide a monitored supply. The battery plays an important role in power conditioning and provides a continuous source of power in the event of a power outage.

Note: The power supply will not detect the backup battery if the power supply is off when the backup battery is connected. The power supply must be on when the backup battery is connected in order to detect its presence.

It is recommended that a minimum of a 7Ah battery is used as the main backup battery.

## Connecting The Battery

From the accessory bag provided:

1. Connect the **red** and **black** battery termination wires to the B+ and B- plugs.
2. Connect the spade terminals to the battery as shown below.

Connection of the battery in reverse will not damage the power supply, but will cause the battery circuit to disconnect until correct connection is made.

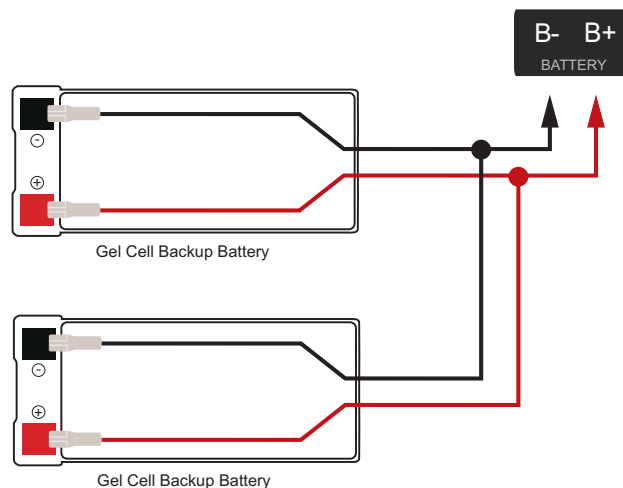

### Warning:

- Only attach standard lead acid batteries.
- Do not connect the battery wires or B+ and B- plugs of the module to any other ancillary device (siren, lock, mag clamp, etc.).
- An incorrect connection may cause erroneous faults or serious damage to the module and will **VOID ALL WARRANTIES OR GUARANTEES**.

The battery test procedure uses a special algorithm to prevent deep discharge and increase battery endurance. A dynamic battery test is performed every ten minutes when mains power is present, and a battery condition alarm will be generated if the battery is either disconnected or shows poor capacity. Battery fault conditions will activate the battery trouble input associated with the address assigned to the power supply.

In addition to the dynamic battery test procedure, the power supply performs a battery presence test every 60 seconds, which determines whether the presence of a backup battery is detected. Similarly, if no backup battery is detected a battery condition alarm will be generated and the battery trouble input associated with the address assigned to the power supply will also be activated.

To comply with EN 50131-1 only one battery can be connected and monitored per system. If more capacity is required a single larger battery must be used.

## Backup Battery Thresholds

The battery disconnection threshold is 8V. Upon reconnection of mains power the power supply automatically detects the backup battery and begins controlled charging at 500mA (typical).



# Encrypted Module Network

The power supply incorporates encrypted RS-485 communications technology. Network power is supplied by the N+ and N- terminals. Connection of the communications and network power should be performed according to the diagram shown. It is important that the N+ network communications power be 12VDC supplied from an independent battery backed power supply unit or a networked module capable of supplying the required voltage to all devices on the RS-485 network.

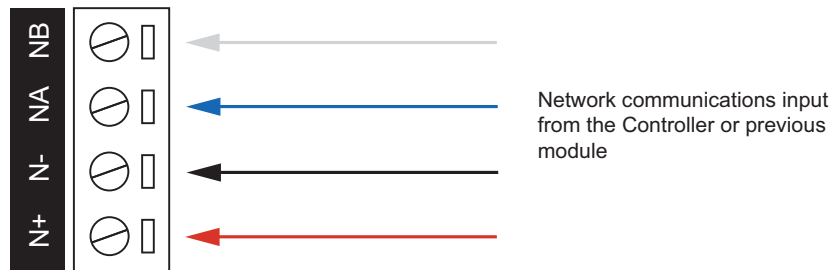

Always connect the power supply NA and NB terminals to the NA and NB terminals of the communication network.

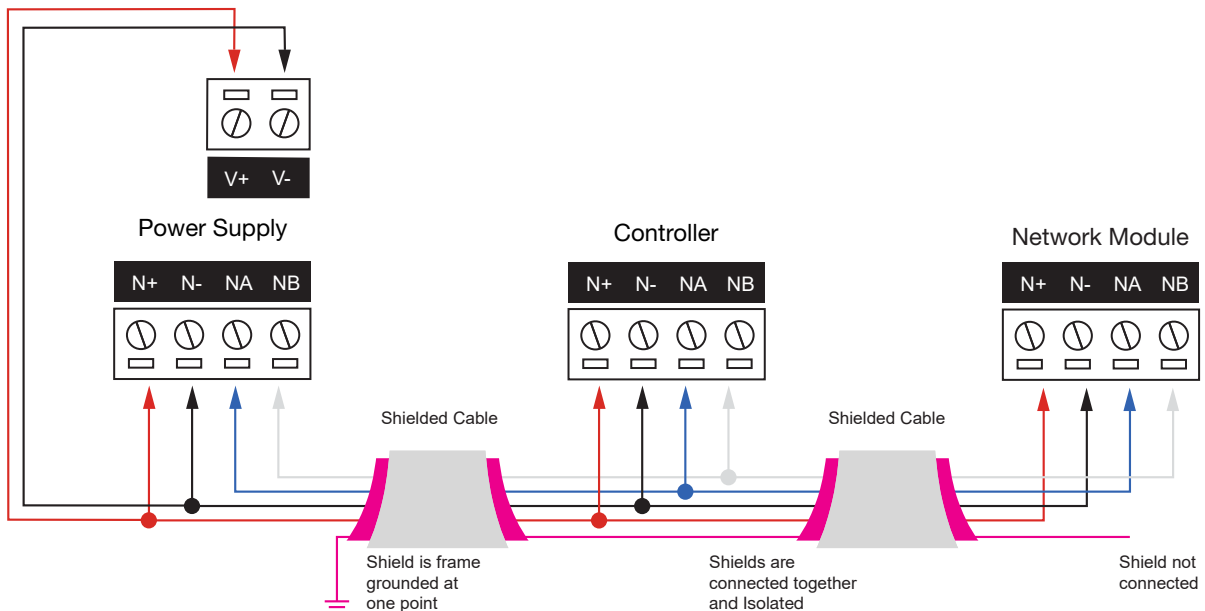

The diagram above shows how a single power supply can be connected to supply the module network. This connection is suitable for smaller systems, provided that the following values are all lower than or equal to the values outlined in the Technical Specifications section of this manual:

- Maximum total output current,
- AUX DC output current,
- Controller bell DC output current, and
- Total combined current

If any of these currents are exceeded, a separate power supply must be used, as shown below.

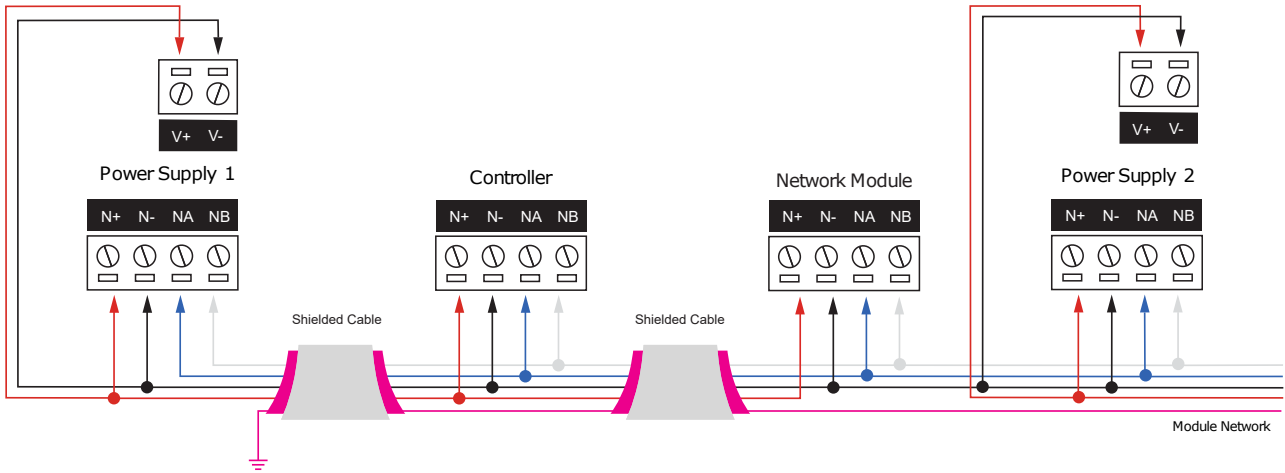

The 12V N+ and N- communication input must be supplied from only **one** point. Connections from more than one 12V supply may cause failure or damage to the unit or the device supplying network power.

## Module Wiring

The recommended module network wiring specifications are:

- Belden 9842 or equivalent
- 24AWG twisted pair with characteristic impedance of 120 ohm
- Maximum total length of cable is 900m (3000ft)
- CAT5e / CAT6 are also supported for data transmission when using ground in the same cable (to a maximum length of 100m (328ft))

**Warning:** Unused wires in the cable must not be used to carry power to other devices.

## End of Line (EOL) Resistors

The 330 ohm EOL (End of Line) resistor provided in the accessory bag **must** be inserted between the NA and NB terminals of the **first** and **last** modules on the RS-485 network. These are the modules physically located at the ends of the RS-485 network cabling.

First Module on RS-485 Network

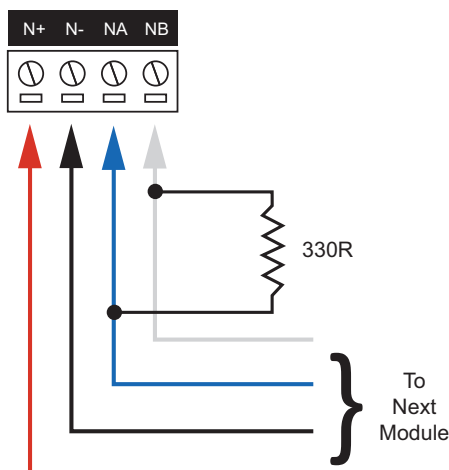

Last Module on RS-485 Network

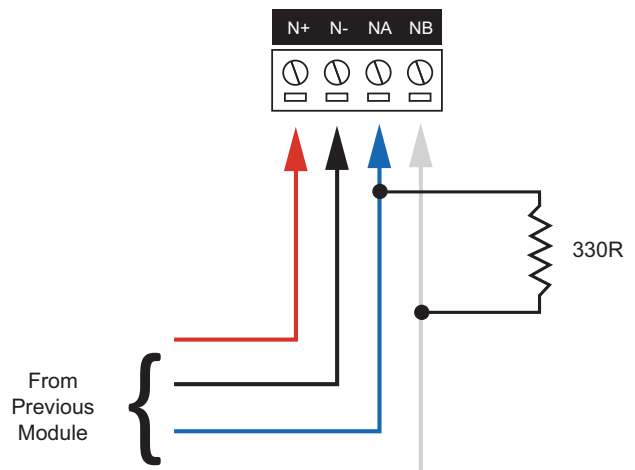

# Output Load Connection

The power supply provides two sets of 12VDC output terminals, V1+ and V2+.

Both V1+ and V2+ outputs are individually fused, with 6 terminals associated to each output and its individual fuse.

A maximum current output of 6.0 amps at 12VDC can be provided across each output at any time. However, if a single current output of 8.0 amps is required, both outputs need to be connected together in parallel.

When any inductive load, including electric locking devices, is powered (directly or indirectly) by the power supply a reverse EMF protection diode must be placed across the positive (V1+ or V2+) and negative (V-) terminals at the device.

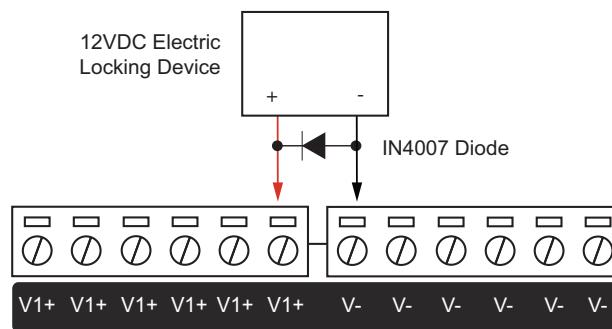

Note: The 1N4007 diode shown **must** be installed across the + and - terminals of any inductive load such as electric locks, magnetic or motorized devices.

## Output Current Influence on Output Load Operation

The table below helps illustrate how the total output current drawn from the power supply module influences the operation of V1 and V2 outputs.

Output Load Operation Status	Output Load Current		
	0 - 8.0A	8.0-8.2A	8.2A - Short Circuit
Outputs Enabled (Mains Power)	✓	✓	
Outputs Supplied by Battery	✓	✓	
Output Over-Current Failure Trouble Input Activated		✓	✓
Over-Current Output Shutdown Activated			✓

## Core Temperature on Output Load Operation

The table below helps illustrate how the core temperature of the power supply module influences the operation of the V1 and V2 outputs.

Output Load Operation Status	Core Temperature		
	<70°C	70-80°C	>80°C
Outputs Enabled (Mains Power)	✓	✓	
Outputs Supplied by Battery	✓	✓	✓
Output Over-Current Failure Trouble Input Activated		✓	✓
Over-Current Output Shutdown Activated			✓

# Inputs

---

The power supply has no physical input connections.

## Trouble Inputs

Each power supply can monitor up to 8 trouble inputs.

Trouble inputs are used to monitor the module status and in most cases are not physically connected to an external input.

The following table details the trouble inputs that are configured in the system and the trouble type and group that they activate.

Input Number	Description	Type	Group
AExxx:01	Module Tamper	System Tamper	System
AExxx:02	Mains Failure	Power Fault	General
AExxx:03	Low Battery/Battery Failure	Power Fault	General
AExxx:04	Output Voltage Low	Power Fault	General
AExxx:05	Output Over-Current Failure	Power Fault	General
AExxx:06	Core Temperature Over-Temp Failure	Power Fault	General
AExxx:07	Reserved	None	None
AExxx:08	Module Offline	Module Offline	System

Replace 'xxx' with the appropriate address of the module that you are programming.

The power supply emulates an analog expander module on the Protege module network. This means that all programming, trouble input and output information is stored in and reported by the analog expander records when programming via a Protege keypad or Protege software.

# Outputs

The power supply has two 50mA outputs that can operate as either programmable outputs or as predefined status outputs, depending on the network status of the module on the Protege system.

## Online Mode

Upon successfully completing the initial registration with any Protege system controller, the outputs of the power supply operate in **online mode**. The module will then continue to operate in online mode until a firmware update is carried out. While in online mode the two outputs function as **programmable outputs** and can be used to activate bell sirens, lighting circuits, door locks, relay accessory products and other automation points.

## Programmable Outputs

The 2 programmable outputs each have a 50mA solid-state relay.

The connection example below shows the control of an external LED indicator.

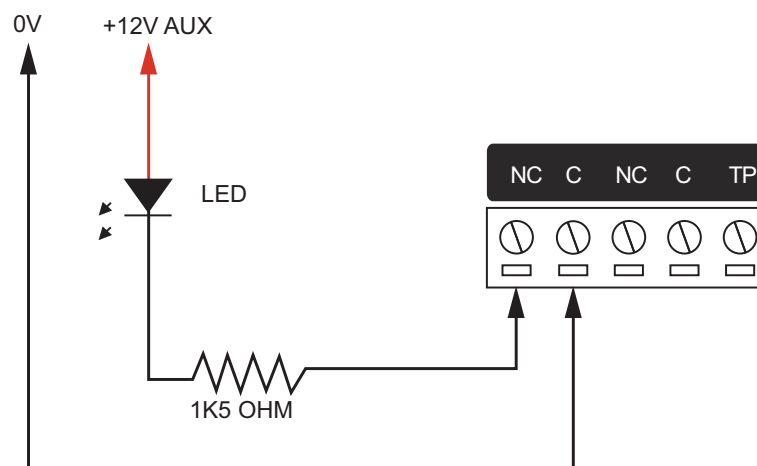

**Warning:** Switching inductive loads that can produce high back EMF voltages or large voltage-induced spikes can cause the module to behave unexpectedly and should be avoided. A suitable isolation circuit must be installed between the relay contacts of the module and the inductive load.

These outputs are rated for low power use only (50mA, 12V Max). Incorrect use may cause erroneous faults or serious damage to the power supply and will **VOID ALL WARRANTIES OR GUARANTEES**.

## Offline Mode

Until connection to a Protege system controller is established, the outputs of the power supply operate in **offline mode**. While in offline mode the two outputs function as **status outputs**. In addition to the comprehensive front panel diagnostic indicators, these status outputs offer additional information that can aid the installer in diagnosing faults and conditions.

## AC Fail Status Output

The AC fail status output has a solid-state relay. The output relay contacts disconnect (normally open) when AC power is removed and the unit remains running on backup battery power. Upon restoring AC power the output relay will revert back to its default state (normally closed).

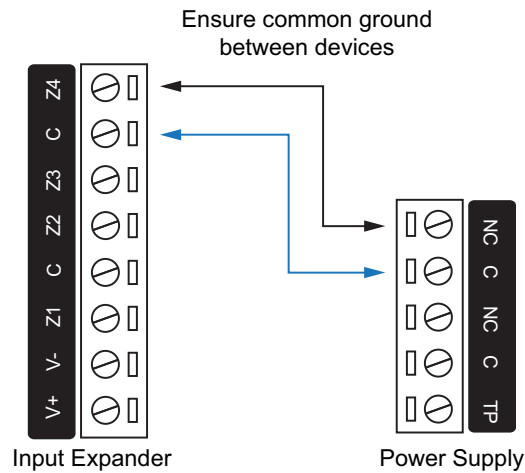

This output is suited for connection to an input on a Protege module with spare inputs available so that the power supply AC status can be externally monitored. The connection example above shows monitoring of the AC status set up in conjunction with a Protege input expander.

## Battery Fail Status Output

The battery fail status output has a solid-state relay. The output relay contacts disconnect (normally open) when either the backup battery has been disconnected or the power supply is running on backup battery power without AC power and the backup battery voltage drops below 11.75V.

Upon reconnecting a backup battery with a voltage greater than 12.5V the output relay will revert back to its default state (normally closed).

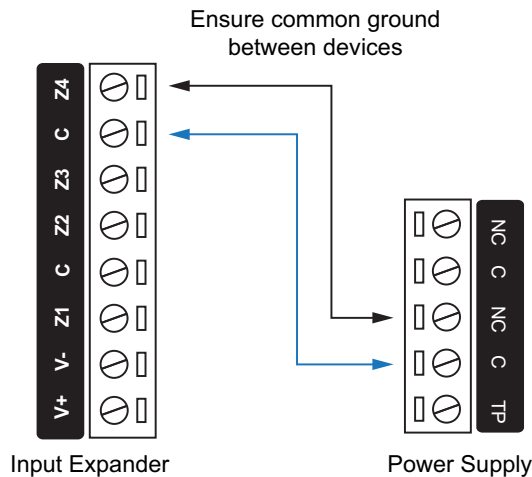

This output is suited for connection to an input on the Protege system for early detection of complete power failure. The connection example above shows monitoring of the battery status set up in conjunction with an input expander.

These outputs are rated for low power use only (50mA, 12V Max). Incorrect use may cause erroneous faults or serious damage to the power supply and will **VOID ALL WARRANTIES OR GUARANTEES**.

# Intelligent Monitoring

---

The power supply is able to relay information about critical system voltages, currents and temperature to the Protege GX controller by registering as an analog expander module on the Protege network. The controller can then store these values in variables that can be viewed live from the Protege GX interface.

This feature is not available in Protege WX.

## Monitoring Setup

The power supply will register with the Protege GX controller as an analog expander module, AExxx.

The channels for each power supply will monitor:

- Channel 1: Voltage at V2+ output
- Channel 2: Voltage at V1+ output
- Channel 3: Power supply module core voltage
- Channel 4: Total current output

Each channel can be associated with a data value and each data value assigned to a variable. These variables can then be monitored on a status page or floor plan.

The **Log Channel Data** option may also be selected to view the raw data as it is received in the event log. However, this will create a large number of events and should only be used for verifying the reception of data.

For more information on programming this feature, see the Protege GX Operator Manual.



# Address Configuration

---

The module address is configured via programming and will require knowledge of the module serial number. The serial number can be found on the identification sticker on the product.

Refer to the Protege system controller installation manual for address programming details.

The controller has a set limit on the number of modules of each type that it can support. When adding and configuring modules always refer to the *Maximum Module Addresses* table in the controller installation manual.

# LED Indicators

---

Protege DIN rail modules feature comprehensive diagnostic indicators that can aid the installer in diagnosing faults and conditions. In some cases an indicator may have multiple meanings depending on the status indicator display at the time.

## Status Indicator

The status indicator displays the module status.

State	Description
Fast flash (green)	Module attempting registration with controller
Slow flash (green)	Module successfully registered with controller
Flashing (red)	Module communications activity

When the fault and status indicators are flashing alternately, the module is in identification mode, enabling the installer to easily identify the module in question. Upon either a module update or the identification time period expiring, the module will return to normal operation.

## Fault Indicator

The fault indicator is lit any time the module is operating in non-standard mode. If the fault indicator is flashing, the module requires a firmware update or is in firmware update mode. When the fault indicator is on, the status indicator will flash an error code.

State	Description
Continuous slow flash (red)	Module is in boot mode awaiting firmware update
Constantly on (red)	Module is in error state and will flash an error code with the status indicator

## Power Indicator

The power indicator is lit whenever the correct module input voltage is applied across the mains input terminals.

State	Description
Constantly on	Correct module input voltage applied
Constantly off	Incorrect module input voltage applied

## V1 Output/V2 Output Indicators

The V1 and V2 output indicators show the status of the 12VDC output.

State	Description
On (green)	12VDC output operating OK
Flashing (red)	12VDC output failure

## Battery Indicator

The battery indicator shows the status of the backup battery.

State	Description (with mains power connected - power indicator on)
Flashing (red)	Backup battery is disconnected
On (red)	Backup battery failed its dynamic battery test
On (green)	Last backup battery dynamic test successful
State	Description (with mains power disconnected - power indicator off)
Flashing (red)	Mains has failed and the PSU is drawing power from the battery. State is Battery Low
Flashing (green)	Mains has failed and the PSU is drawing power from the battery. State is Battery Restore

## Temp Indicator

The temp indicator shows the status of the unit's core temperature.

State	Description
On (red)	Core temperature exceeded. <b>Over Temp Shutdown Activated</b>
Flashing (red)	Core temperature within 10°C of Over Temp Shutdown
On (green)	Core temperature OK

## Output Current Indicator

The output current indicator shows the status of the output current for both V1+ and V2+.

State	Description
Constantly on	Output current exceeded. <b>Over Current Shutdown Activated</b>
Continuous flash	Output current exceeded maximum, approaching Over Current Shutdown
Constantly on (all indicators)	Maximum output current level reached
Constantly on (partial)	Indicated output current level reached

# Error Code Indication

---

When the module attempts to register or communicate with the system controller a registration error can be generated indicating that it was not successful.

## Error Code Display

The following table is only valid if the **fault** indicator is constantly on and the **status** indicator is flashing red.

If the fault indicator is flashing the module requires a firmware update or is currently in firmware update mode.

The status indicator will flash red with the error code number. The error code number is shown with a 250ms on and off period (duty cycle) with a delay of 1.5 seconds between each display cycle.

Flash	Error Description
1	<b>Unknown Error Code</b> The error code returned by the system controller could not be understood by the module.
2	<b>Firmware Version</b> The firmware version on the module is not compatible with the system controller. To clear this error, update the module using the module update feature in the controller's web interface.
3	<b>Address Too High</b> The module address is above the maximum number available on the system controller. To clear this error change the address to one within the range set on the system controller, restart the module by disconnecting the power.
4	<b>Address In Use</b> The address is already in use by another module. To clear this error set the address to one that is not currently occupied. Use the view network status command to list the attached devices, or the network update command to refresh the registered device list.
5	<b>Controller Secured Registration Not Allowed</b> The controller is not accepting any module registrations. To allow module registrations use the network secure command to change the setting to not secured.
6	<b>Serial Number Fault</b> The serial number in the device is not valid. Return the unit to the distributor for replacement.
7	<b>Locked Device</b> The module or system controller is a locked device and cannot communicate on the network. Return the unit to the distributor for replacement.

# Mechanical Diagram

The mechanical diagram below outlines the essential details needed to help ensure the correct installation of the power supply.

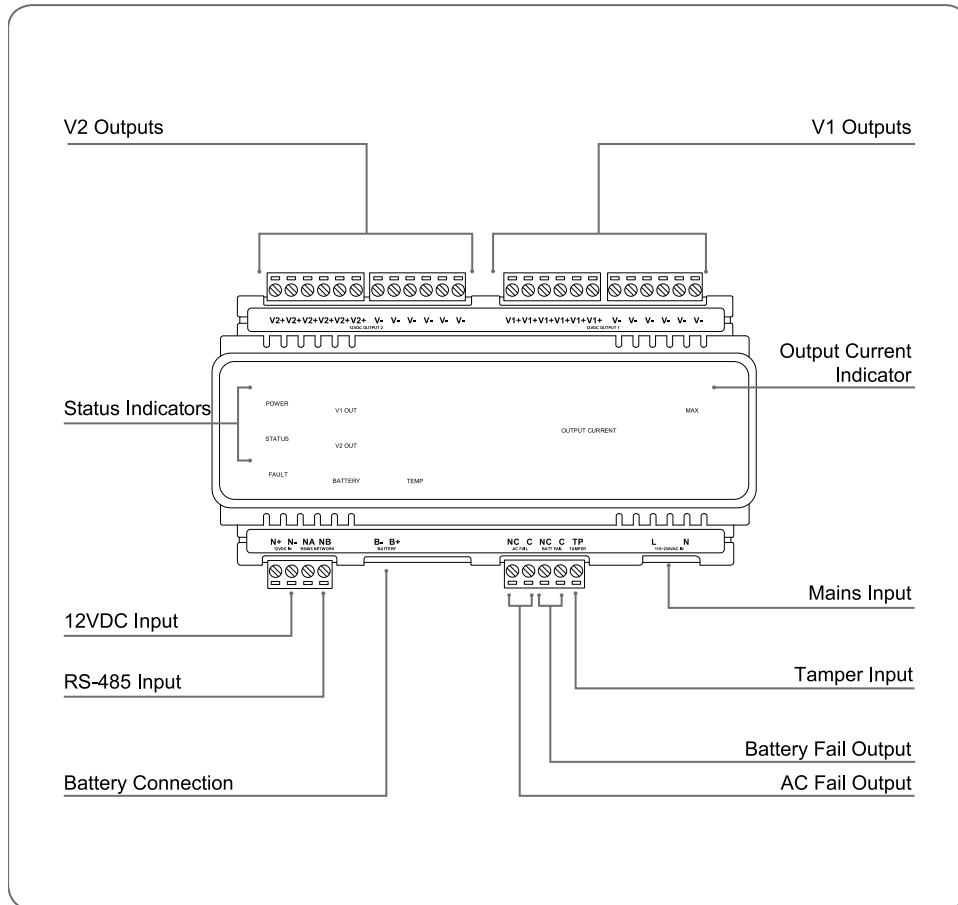

# Mechanical Layout

The mechanical layout below outlines the essential details needed to help ensure correct installation and mounting. All measurements are shown in millimeters.

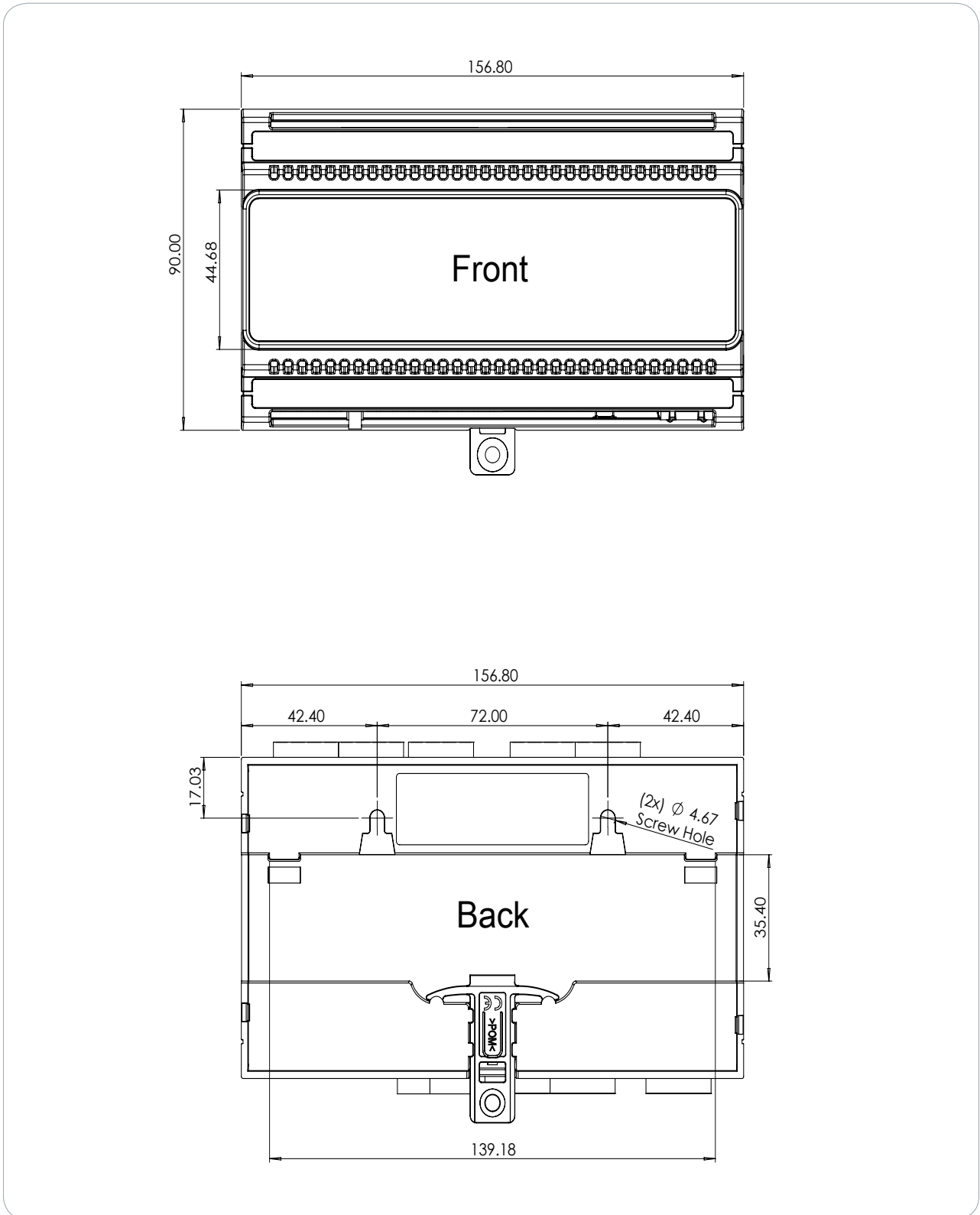

# Technical Specifications

The following specifications are important and vital to the correct operation of this product. Failure to adhere to the specifications will result in any warranty or guarantee that was provided becoming null and void.

Ordering Information	
PRT-PSU-DIN-8A	Protege DIN Rail 8A Intelligent Power Supply
Power Supply	
Mains Input Voltage	120VAC (90-264VAC, 47-63Hz)
Mains Input Operating Current	120VAC 2.5A (Full Load)
DC Output (Combined)	12.64VDC 7.5A Max (V1 Out + V2 Out Total)
DC Output (Single)	12.2VDC 5A Max
Battery Charging	500mA (Typical) *Additional to the 7.5A Combined DC Output
Battery Low	11.75VDC
Battery Restore	12.5VDC
Communication	
RS-485	Isolated Module Network
Outputs	
Outputs	2 Solid-State Relay Outputs, 50mA 12V Max each
Inputs	
Tamper	Dedicated Hardware Tamper Input
Trouble Inputs	8 (internal)
Dimensions	
Dimensions (L x W x H)	156 x 90 x 60mm (6.14 x 3.54 x 2.36")
Net Weight	460g (16.2oz)
Gross Weight	570g (20.1oz)
Operating Conditions	
Operating Temperature	-10° to 55°C (14° to 131°F)
Storage Temperature	-10° to 85° C (14° to 185° F)
Humidity	0%-93% non-condensing, indoor use only (relative humidity)
Mean Time Between Failures (MTBF)	217,030 hours (calculated using RFD 2000 (UTE C 80-810) Standard)

It is important that the unit is installed in a dry cool location that is not affected by humidity. Do not locate the unit in air conditioning or a boiler room that can exceed the temperature or humidity specifications.

Integrated Control Technology continually strives to increase the performance of its products. As a result these specifications may change without notice. We recommend consulting our website ([www.ict.co](http://www.ict.co)) for the latest documentation and product information.

# New Zealand and Australia

---

## General Product Statement

The RCM compliance label indicates that the supplier of the device asserts that it complies with all applicable standards.





# European Standards

---

## CE Statement

Conforms where applicable to European Union (EU) Low Voltage Directive (LVD) 2014/35/EU, Electromagnetic Compatibility (EMC) Directive 2014/30/EU, Radio Equipment Directive (RED) 2014/53/EU and RoHS Recast (RoHS2) Directive: 2011/65/EU + Amendment Directive (EU) 2015/863.

This equipment complies with the rules, of the Official Journal of the European Union, for governing the Self Declaration of the CE Marking for the European Union as specified in the above directive(s).



### Information on Disposal for Users of Waste Electrical & Electronic Equipment

This symbol on the product(s) and / or accompanying documents means that used electrical and electronic products should not be mixed with general household waste. For proper treatment, recovery and recycling, please take this product(s) to designated collection points where it will be accepted free of charge.

Alternatively, in some countries you may be able to return your products to your local retailer upon purchase of an equivalent new product.

Disposing of this product correctly will help save valuable resources and prevent any potential negative effects on human health and the environment, which could otherwise arise from inappropriate waste handling.

Please contact your local authority for further details of your nearest designated collection point.

Penalties may be applicable for incorrect disposal of this waste, in accordance with your national legislation.

### For business users in the European Union

If you wish to discard electrical and electronic equipment, please contact your dealer or supplier for further information.

### Information on Disposal in other Countries outside the European Union

This symbol is only valid in the European Union. If you wish to discard this product please contact your local authorities or dealer and ask for the correct method of disposal.

## EN50131 Standards

This component meets the requirements and conditions for full compliance with EN50131 series of standards for equipment classification.

EN 50131-1:2006+A2:2017, EN 50131-3:2009, EN 50131-6:2008+A1:2014, EN 50131-10:2014, EN 50136-1:2012, EN 50136-2:2013, EN 60839-11-1:2013

### Security Grade 4

### Environmental Class II

Equipment Class: Fixed

Readers Environmental Class: IVA, IK07

SP1 (PSTN – voice protocol)

SP2 (PSTN – digital protocol)

SP6 (LAN – Ethernet) and DP1 (LAN – Ethernet + PSTN)

SP6 (LAN – Ethernet) and DP1 (LAN – Ethernet + USB-4G modem)

**Tests EMC (operational)** according to EN 55032:2015

**Radiated disturbance** EN 55032:2015

**Power frequency magnetic field immunity tests** (EN 61000-4-8)

**Power Supply Type A** (EN 50130-4 ed. 2)

**Mains supply voltage variations** (EN 50130-4 ed. 2)

**Mains supply voltage dips and short interruption** (EN 50130-4 ed. 2, EN 61000-4-2 ed. 2)

**Electrostatic discharge** (EN 50130-4 ed. 2, EN 61000-4-2 ed. 2)

**Contact discharges**  $\pm 6$  kV, Air discharges to  $\pm 8$  kV

**Radiated electromagnetic fields** (EN 50130-4 ed. 2, EN 61000-4-3 ed.3)

**Conducted disturbances induced by electromagnetic fields** (EN 50130-4 ed. 2, EN 61000-4-6)

**Fast Transient bursts** (EN 50130-4 ed. 2, EN 61000-4-4 ed.2)

To the AC mains supply lines applied disturbance signal voltage level 2 kV both polarities for 1 minute. To other supply / signal lines applied by the capacitive clamp injection method disturbance signal voltage level 1 kV for both polarities for 1 minute.

**Slow high energy voltage surge** (EN 50130-4 ed. 2, EN 61000-4-5 ed.2)

To comply with EN 50131-1, EN 60839-11 Security Grade 4 and AS/NZS2201.1 class 4&5 Vibration Detection for PreTamper Alarm, protection is provided by a DSC SS-102 Shockgard Seismic vibration sensor mounted within the system enclosure. Alarm output is provided by a pair of non-latching, N.C. (normally closed) relay contacts, opening for a minimum of 1 second on detection of an alarm connected in series with the 24Hr tamper input (TP) on the PSU (or any other system input designated/programmed as a 24Hr Tamper Alarm).

This relay is normally energized to give fail-safe operation in the event of a power loss. Indication of detection is provided by a LED situated on the front cover. The vibration sensor is fully protected from tampering by a N.C. micro switch operated by removal of the cover.

Enclosure EN-DIN-24 has been tested and certified to EN50131.

By design, the enclosures for all Integrated Control Technology products, EN-DIN-11, EN-DIN-12 and EN-DIN-24-ATTACK, comply with the EN 50131 standards. Tamper protection against removal of the cover as well as removal from mounting is provided by tamper switch.

**Warning: Enclosures supplied by 3rd parties may not be EN50131-compliant, and should not be claimed as such.**

To comply with EN 50131-1 only one battery can be connected and monitored per system. If more capacity is required a single larger battery must be used.

# UK Conformity Assessment Mark

---

## General Product Statement

The UKCA Compliance Label indicates that the supplier of the device asserts that it complies with all applicable standards.



# FCC Compliance Statements

---

## FCC Rules and Regulations CFR 47, Part 15, Subpart B

This equipment complies with the limits for a Class A digital device, pursuant to Part 15 of the FCC rules.

Operation is subject to the following two conditions:

- This device may not cause harmful interference.
- This device must accept any interference received, including interference that may cause undesired operation.

NOTE: THE GRANTEE IS NOT RESPONSIBLE FOR ANY CHANGES OR MODIFICATIONS NOT EXPRESSLY APPROVED BY THE PARTY RESPONSIBLE FOR COMPLIANCE. SUCH MODIFICATIONS COULD VOID THE USER'S AUTHORITY TO OPERATE THE EQUIPMENT.

# Industry Canada Statement

---

## ICES-003

This class A digital apparatus complies with Canadian ICES-003.

Cet appareil numérique de la classe A est conforme à la norme NMB-003 du Canada.

CAN ICES-3 (A)/NMB-3(A)

# Disclaimer and Warranty

---

**Disclaimer:** Whilst every effort has been made to ensure accuracy in the representation of this product, neither Integrated Control Technology Ltd nor its employees shall be liable under any circumstances to any party in respect of decisions or actions they may make as a result of using this information. In accordance with the ICT policy of enhanced development, design and specifications are subject to change without notice.

For warranty information, see our [Standard Product Warranty](#).

Designers & manufacturers of integrated electronic access control, security and automation products.  
Designed & manufactured by Integrated Control Technology Ltd.  
Copyright © Integrated Control Technology Limited 2003-2022. All rights reserved.

**Disclaimer:** Whilst every effort has been made to ensure accuracy in the representation of this product, neither Integrated Control Technology Ltd nor its employees shall be liable under any circumstances to any party in respect of decisions or actions they may make as a result of using this information. In accordance with the ICT policy of enhanced development, design and specifications are subject to change without notice.