

P/N 100054 EZ-RJPRO™ HD Crimp Tool Blade Replacement

The following is a written guide on replacing the cutting blade for the RJ45 cavity on the 100054 EZ-RJ-PRO HD Crimp Tool.

1. Locate the blade in the RJ45 crimping cavity. Using a Phillips head screwdriver, remove the screw from the housing.

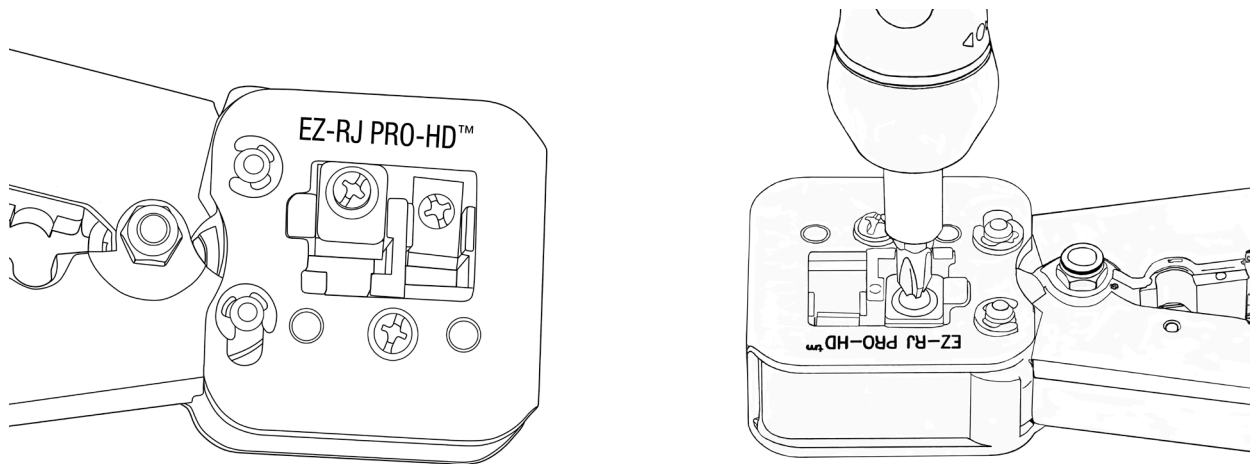

2. Once the screw has been removed, remove the front plate and set aside. Note: the front plate does have a front and a back side. The side pressed on the blade is flat and the screw side is rounded.

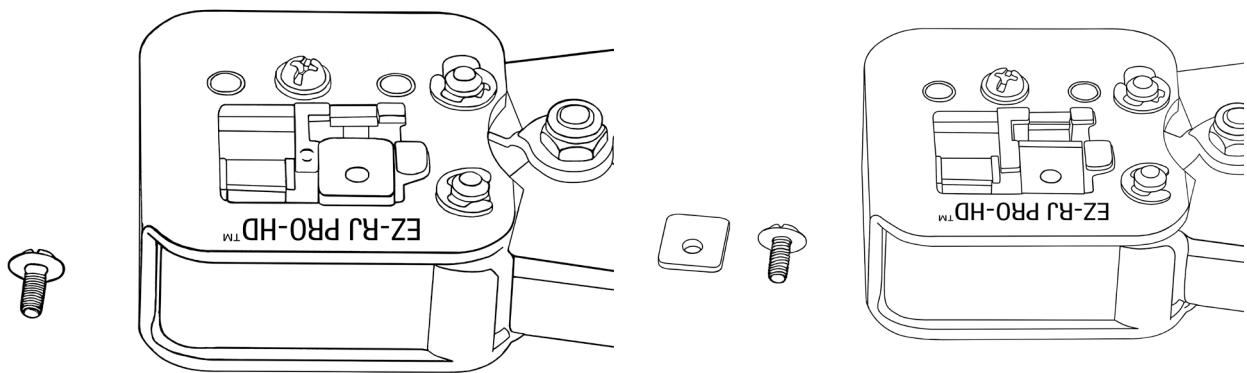

3. After removal of the front plate, remove the blade. Note the orientation of the blade. Once the blade has been removed, note the small spacer under the blade. This piece does not need to be removed to replace the blade. Although note that this piece has a specific orientation. The space from the screw hole is smaller on top than on the bottom.

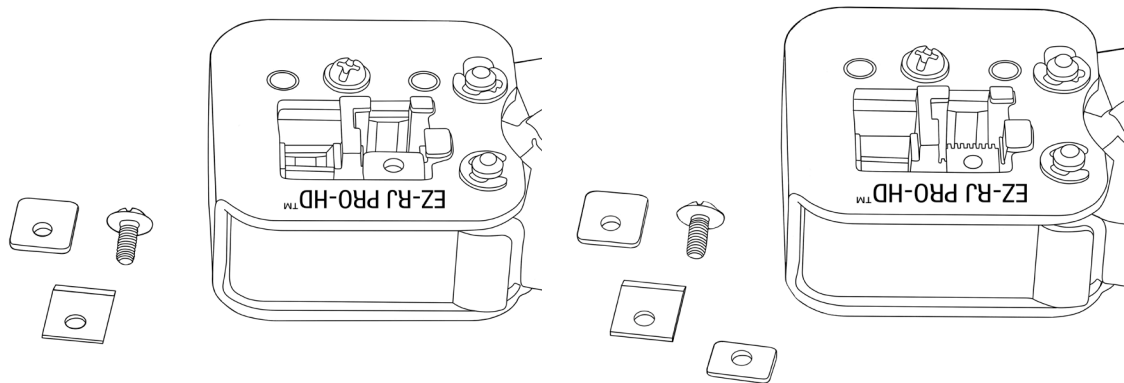

4. Place the new blade into tool ensuring the spacer is oriented correctly, the flat side of the blade is face down, and the angled side is showing.

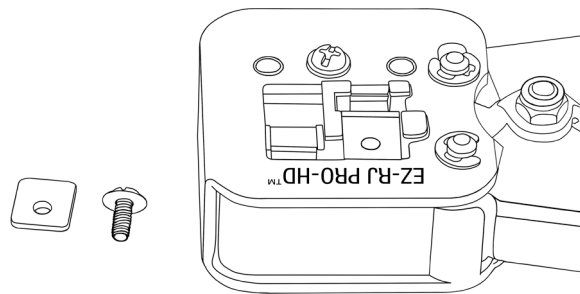

5. Orient the front plate with the flat side against the blade and all holes lining up. Insert screw and slightly tighten the screw with the screwdriver. The blade should still be loose.

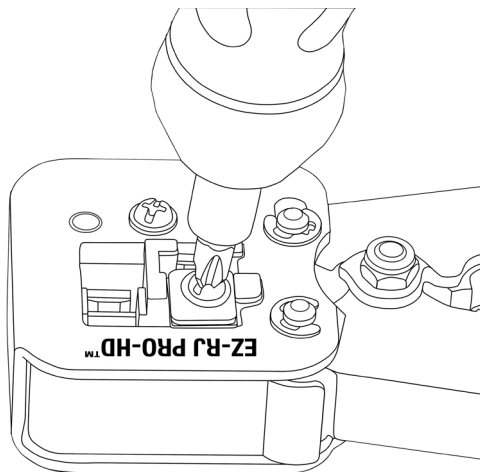

6. Once the screw has been tightened enough to leave the blade still loose, insert a crimped EZ-RJ45 Connector and cycle the tool down to the last ratchet point.

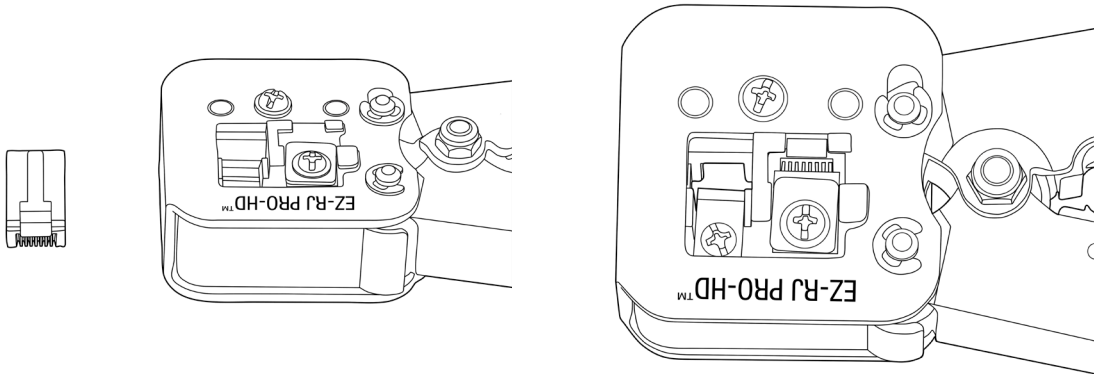

7. Once the tool is locked in the last ratchet position, use the screw driver to fully tighten blade with connector in place. This process aligns the blade properly for the next termination.

