

SECO-LARM®

Surface-Mount Electric Rim Strikes

Installation Manual



SD-998C-D3AQ shown



Model	Housing thickness	Latch Throw	Material
SD-998C-D3Q	3/4" (19mm)	3/4" (19mm)	Aluminum
SD-998C-BD3	3/4" (19mm)	3/4" (19mm)	Black (Anodized)
SD-998C-D3AQ	1/2" (13mm)	1/2" (13mm)	Aluminum
SD-998C-BD3A	1/2" (13mm)	1/2" (13mm)	Black (Anodized)

- 12/24 VDC Operating voltage
- Non-polarized connection
- Horizontal adjustment
- Accommodates up to 3/4" Pullman latch
- Reversible non-handed design fits either right-hand or left-handed doors
- Surface-mount on metal or wood frames
- Works with standard rim-type exit devices including SECO-LARM SD-962xR-36A and SD-962xR-36G
- For Indoor Use Only
- Static strength – 1,500-lb (6673N)
- Tested for 250,000 cycles (UL Tested)
- Low current draw: 540mA@12VDC, 270mA@ 24VDC
- Field-selectable for fail-safe or fail-secure operation
- The SD-998C series is intended to be used with UL Listed Exit Hardware
- The SD-998C series shall not impair the intended operation of an emergency unit
- The SD-998C series shall not impair the operation of panic hardware mounted on the door

Parts List

- | | |
|-------------------------------|-------------------------------------|
| 1x Strike | 1x Dead latch ramp adapter |
| 1x Blind nut kit | 1x 12VDC cable connector |
| 2x Blind nuts | 1x 24VDC cable connector |
| 1x Hex wrench | Spacers |
| 2x Hex socket head cap screws | 3x 1/32" (0.9mm)* |
| 2x Phillips flat head screws | 1x 1/16" (1.5mm) 2x 1/8" (3mm) † |
| 2x Crimp connectors | |

*SD-998C-D3Q and SD-998C-BD3 only

†SD-998C-D3AQ and SD-998C-BD3A only

Specifications

Model	SD-998C-D3Q	SD-998C-BD3	SD-998C-D3AQ	SD-998C-BD3A
Operating voltage	12~24 VDC			
Current draw	540mA@12VDC, 270mA@24VDC			
Maximum latch throw	3/4" (19mm)		1/2" (13mm)	
Static strength	1,500-lb (6673N)			
Dynamic strength	70ft-lb (95J)			
Endurance	250,000 cycles (UL Tested), Level IV			
Destructive attack	Level I			
Line security	Level I			
Standby power	Level I			
Operating humidity	0~85%			
Operating temperature	14°~120° F (-10°~49° C)			
Dimensions	9"x3/4"x13/4" (229x19x45 mm)		9"x1/2"x13/4" (229x13x45 mm)	

Overview

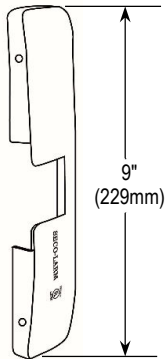
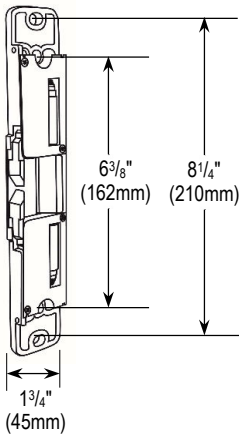

Cover

SD-998C-D3Q
SD-998C-BD3

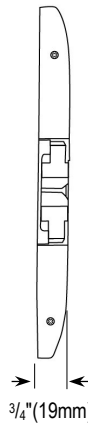

SD-998C-D3AQ
SD-998C-BD3A

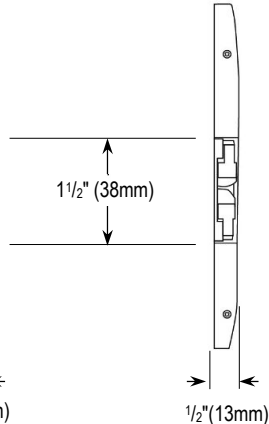

Installation

1. Set either fail-safe or fail-secure operation. See "Selecting Fail-Safe/Fail-Secure," below.
2. Measure the center line of the latch, labeled "Y" (see Fig.1).
3. With the door closed, measure and mark the latch line on the door frame, labeled "X" (see Fig. 2). This will correspond with the inside of the strike keeper as shown in Figs. 3 and 4.
4. Remove the four cover screws and remove the cover.
5. Using the strike as a template centered on the latch center line "Y," and so that the inside of the strike keeper is aligned with the door latch line "X," mark and drill the two outer mounting holes and the cable access hole.
6. Make the wire connections (see "Wiring Diagram" on pg. 4) and then mount the strike to the frame with the Philips flat-head screws. Check the location and ensure that the door latches properly and adjust the strike horizontally as needed.
7. Tighten the two mounting screws and mark the locking hole locations (the two inner holes, see Fig. 5).
8. Remove the strike and drill the two locking holes. Insert the blind nuts into the locking holes. Reinstall the strike as before and lock into place with the hex socket head cap screws into the blind nuts.
9. Replace the cover and reinstall the screws.

Fig. 1

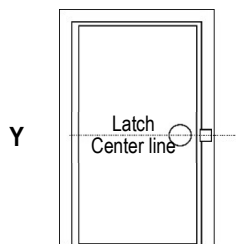

Fig. 2

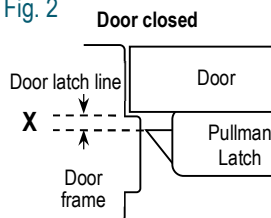

Fig. 3

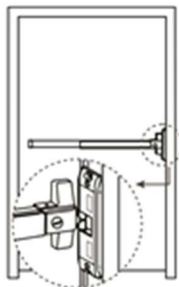

Fig. 4

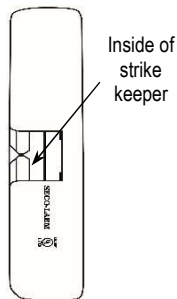
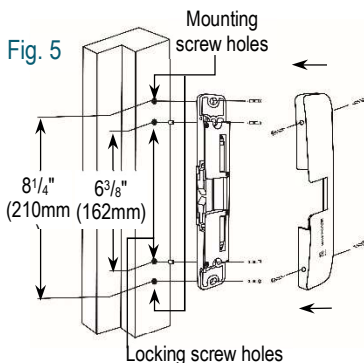

Fig. 5



Selecting Fail-Safe/Fail-Secure

1. Remove both locking screws #1.
2. Loosen both sliding screws #2, slide to the desired fail safe or fail secure setting (factory default), and retighten.
3. Reinsert and tighten locking screws #1 to lock the desired fail safe or fail secure setting.

NOTE: SD-998C-D3AQ SD-998C-BD3A shown.

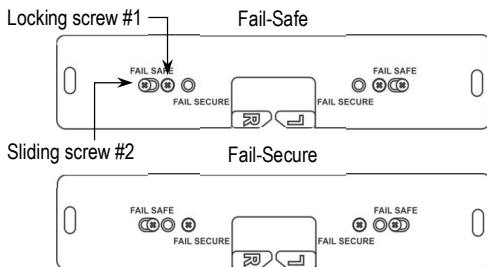

Wiring Diagram

For 12VDC operation

1. Use the included wiring connector marked 12VDC.
2. Plug the male wiring connector into the female wiring harness connector of the door strike.

For 24VDC operation

1. Use the included wiring connector marked 24VDC.
2. Plug the male wiring connector into the female wiring harness connector of the door strike.

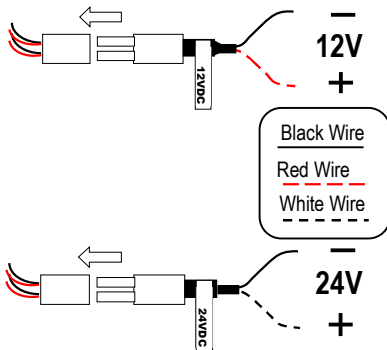

Dead latch Ramp Adapter

1. Remove cover by removing 4 screws.
2. Remove 2 screws holding latch ramp and remove.
3. Install Dead latch ramp adapter and replace the 2 screws to hold it in place.
4. Replace the cover and replace the 4 screws.

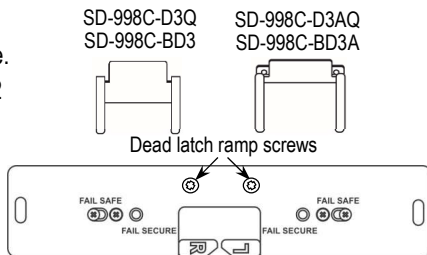

Troubleshooting

Electric strike does not activate

- Dismount the strike and check that the wiring connector is connected properly.
- Ensure the wiring connector is connected to a 12 or 24VDC source.
- Use a multimeter to test that the strike is receiving the proper voltage and amperage. If it is not, it may be necessary to use heavier gauge wires, or increase the output of the power supply.
- Make sure the activation device (keypad or push-button switch) is working properly

Door does not open when the electric strike is activated

- Check that the door latch is operating properly, and replace if necessary.
- The position of the electric strike may need to be adjusted by moving it or adding washers or shims.

Strike makes a buzzing sound

- Connect the strike to a DC power supply.

IMPORTANT: Users and installers of this product are responsible for ensuring that the installation and configuration of this product complies with all national, state, and local laws and codes. SECO-LARM will not be held responsible for the use of this product in violation of any current laws or codes.

California Proposition 65 Warning: These products may contain chemicals which are known to the State of California to cause cancer and birth defects or other reproductive harm. For more information, go to www.P65Warnings.ca.gov.

WARRANTY: This SECO-LARM product is warranted against defects in material and workmanship while used in normal service for one (1) year from the date of sale to the original customer. SECO-LARM's obligation is limited to the repair or replacement of any defective part if the unit is returned, transportation prepaid, to SECO-LARM. This Warranty is void if damage is caused by or attributed to acts of God, physical or electrical misuse or abuse, neglect, repair or alteration, improper or abnormal usage, or faulty installation, or if for any other reason SECO-LARM determines that such equipment is not operating properly as a result of causes other than defects in material and workmanship. The sole obligation of SECO-LARM and the purchaser's exclusive remedy, shall be limited to the replacement or repair only, at SECO-LARM's option. In no event shall SECO-LARM be liable for any special, collateral, incidental, or consequential personal or property damage of any kind to the purchaser or anyone else.

NOTICE: The SECO-LARM policy is one of continual development and improvement. For that reason, SECO-LARM reserves the right to change specifications without notice. SECO-LARM is also not responsible for misprints. All trademarks are the property of SECO-LARM U.S.A., Inc. or their respective owners. Copyright © 2023 SECO LARM U.S.A., Inc. All rights reserved.

SECO-LARM® U.S.A., Inc.

16842 Millikan Avenue, Irvine, CA 92606
Phone: (949) 261-2999 | (800) 662-0800

Website: www.seco-larm.com
Email: sales@seco-larm.com

