

ELK-0613 6V, 1.3 Ah

FEATURES

- Valve regulated, non-spillable construction
- UL recognized component
- Two year over-the-counter warranty

APPLICATIONS

- Back-up battery for security alarm systems, fire alarm systems and access control systems
- Emergency lights
- Lighted exit signs
- Uninterruptible power supplies
- Other general purpose use

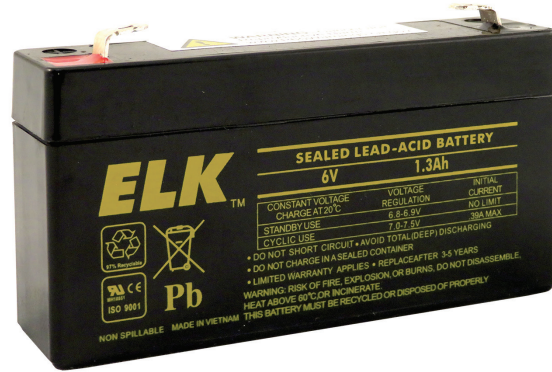

SPECIFICATIONS

Nominal Voltage	6 Volts
Rated Capacity	1.3 Ah (20 hour rate)
Nominal Capacity (77°F, 25°C)	
20 hour rate (0.065A)	1.3Ah
10 hour rate (0.12A)	1.2Ah
5 hour rate (0.21A)	1.05Ah
1 hour rate (0.73A)	0.73Ah
Effect of Temperature on Capacity (20 hour rate)	Note: Prolonged exposure to extreme temperatures can have long term effects on battery performance
104°F (40°C)	102%
77°F (25°C)	100%
32°F (0°C)	85%
5°F (-15°C)	65%
Charge Constant Voltage Cycle	7.0V - 7.5V at 77°F (25°C) Initial Charging Current 0.36A Max
Standby	6.8V - 6.9V at 77°F (25°C)
Weight (Approximate)	0.64 lbs (0.29 kg)
Terminals	F1 Faston Tab (.187")

DIMENSIONS

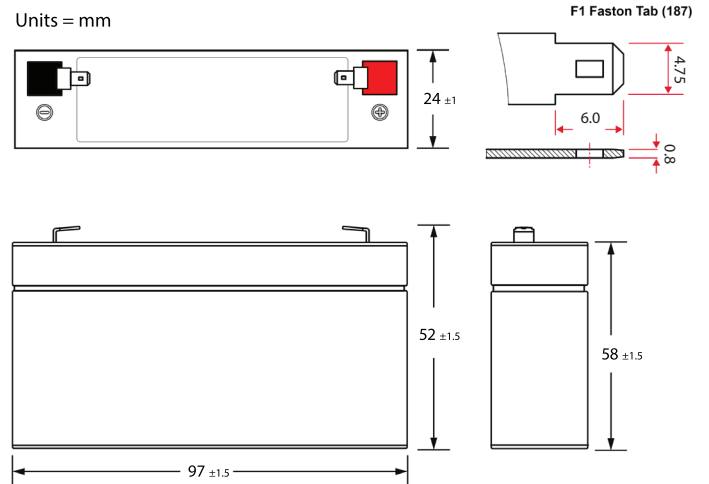

Length	3.82" (97 mm)	Case Height	2.05" (52 mm)
Width	0.94" (24 mm)	Total Height	2.28" (58 mm)

CAPACITY RETENTION CHARACTERISTICS

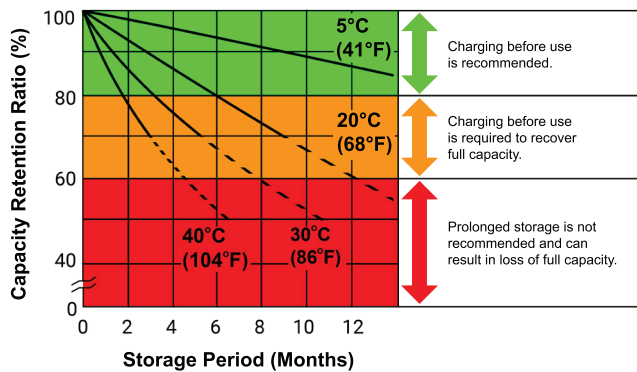

DISCHARGE CHARACTERISTICS (68°F, 20°C)

