

APPLICATION:

The ELK-AEDBHR is an "active" RS-485 data bus hub designed for jobs where an Alarm Engine Control is retrofitting an older panel that has multiple homerun 4 conductor keypad/data wires. It splits the main 485 data bus into 4 managed 485 branches. Each branch can have 2 parallel home run cables for a total of 8 home runs. The AEDBHR is designed with terminating jumpers for each branch. These jumpers, when appropriately paired with terminating jumpers on end-of-line devices, ensure proper operation and supervision.

FEATURES:

- Splits the Alarm Engine RS-485 data bus output into 4 managed branches
- Each managed branch can have 2 parallel home run cables (total of 8 home runs)
- Removable terminal blocks for easy wiring
- Works with standard 4 conductor home run wire
- Includes mounting glides for ELK-SWB boxes

SPECIFICATIONS:

- Inputs: Elevator Screw Terminals, 4 Position
- Output: Elevator Screw Terminals, 4 Position
- Current Draw: 30mA nominal PLUS 20mA per RS485 active branch driver. Total combined with all 4 branches active would be ~110mA.

Note: This is in addition to the power requirements of any connected data bus devices (keypads, expanders, etc.)

- Circuit Board Dimensions: 4" x 2.75"

Features or Specifications subject to change without notice.

Installation

1. The AEDBHR can be mounted inside the Alarm Engine enclosure on the left or right hand side of the Alarm Engine board using the supplied ELK-SWG Circuit Board Glides. If all the mounting locations are consumed, an additional ELK-SWB14 or ELK-SWB28 enclosure may be installed.



The ELK-SWG Circuit Board Glides attach to the enclosure at strategically placed 2-hole punch patterns. Note that one hole in each pattern is slightly larger than the other. The small hole is for a 6/32 type "F" mounting screw and the large hole is for a half-moon shape locator tab on the bottom of each glide.



2. Starting at the top, loosely start a 6/32" mounting screw in the small hole of the first 2-hole pattern. Place the slotted edge of a board glide under this screw, making sure that the half-moon tab fits into the larger hole and the grooved edge is facing down. Tighten the screw using a long shafted screwdriver. Install a second board glide in the 2-hole pattern 4" below. Attach the second board glide using the same procedures. The grooved edge of this glide should face up.
3. Slide the AEDBHR board into the grooves provided by the glides. The circuit board should slide freely. If loose or too tight, simply loosen one of the mounting screws and adjust the glide to assure a good fit.

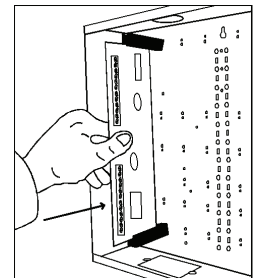

Wiring Connections

1. Turn Control Panel Master Power Switch Off.
2. Use a 4 wire cable to connect the Alarm Engine Data Bus terminals +BUS 12V, Data A, Data B, and Neg from Control to terminals +, A, B, and - on the AEDBHR. NOTE: If existing wires are already attached to the Data Bus terminals, remove them and follow the detailed wiring diagram on the next page. One of the main purposes of the AEDBHR is to connect and distribute most devices and homeruns through it, as opposed to directly to the main control board.
3. Make all connections as per the diagram on the next page. Install terminating jumpers as directed on the next page. Jumpers shunts are included in the ELK-SWG package included with the AEDBHR.
4. Power up the Control.

REMEMBER: Any data bus devices that are added to the Control must be enrolled using the ElkConnect app.

The ELK-AEDBHR Data Bus Hub Retrofit is intended for retrofit jobs where existing 4 conductor cables are the only wires available. It creates 4 managed RS-485 BRANCHES from the single Alarm Engine main RS-485 Bus. Like the main Alarm Engine Bus, each branch can only have 2 home run cables (4 branches x 2 ea. = 8 home runs).

DO NOT connect more than two (2) AEDBHR Hubs to a single Alarm Engine Control.

DO NOT connect an AEDBHR on a branch of another AEDBHR! The AEDBHR CANNOT be used as an extender or remote repeater.

DO NOT remote AEDBHR(s) away from the Alarm Engine. Mount within main enclosure. Terminate last (end line) device on each home run.

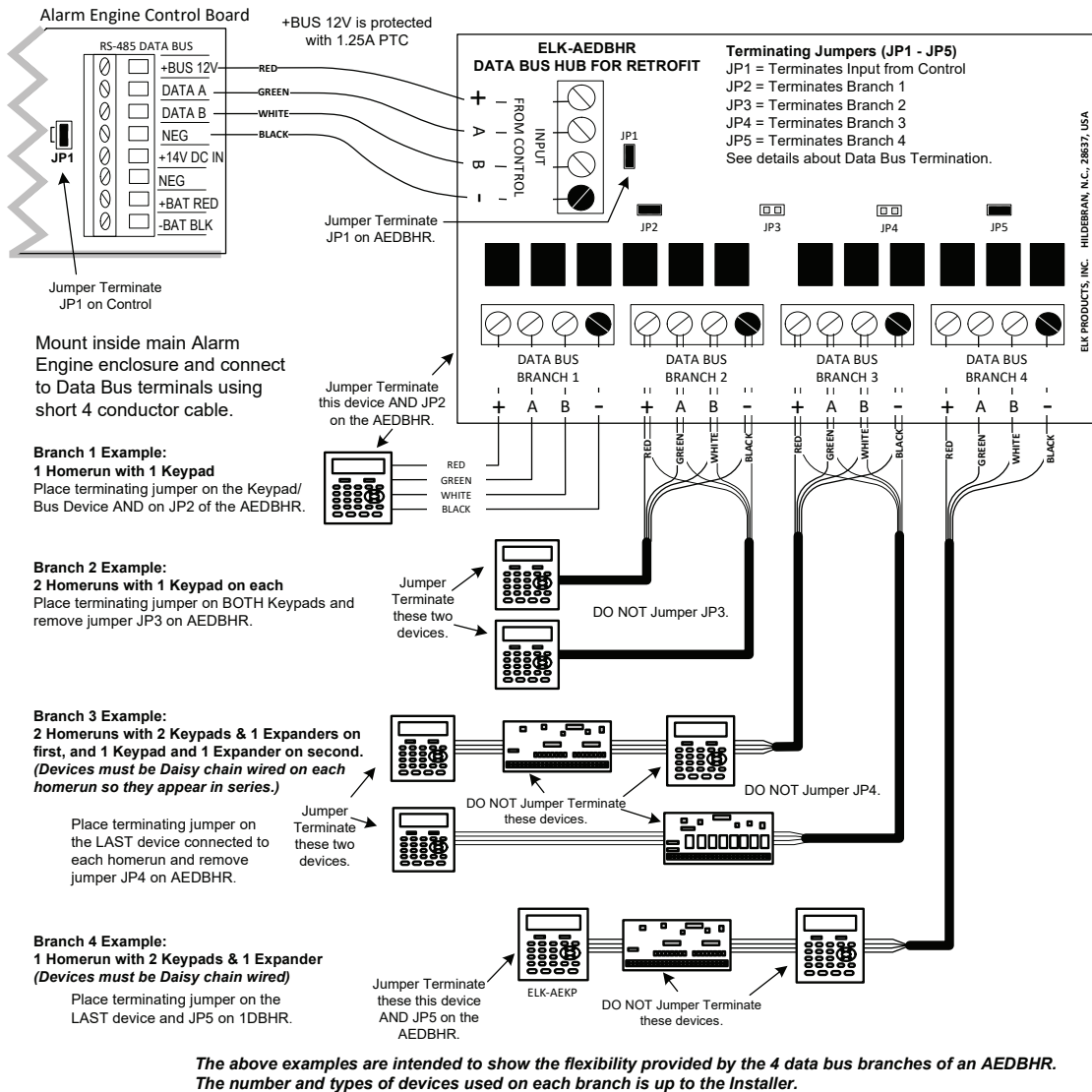

END-OF-LINE DATA BUS TERMINATION IS VERY IMPORTANT !

All bus devices (keypad, expanders, etc.) have terminating jumpers. Placing a shorting header on the jumper engages a 120 Ohm resistor across data A & B lines. Refer to the individual instruction manuals and Control hardware pack for shorting headers.

If using 1 AEDBHR place jumper on JP1 of the AEDBHR and JP3 of the Alarm Engine Control.
With 2 AEDBHR boards place jumper on JP1 of both AEDBHR boards and remove jumper JP3 on the Alarm Engine Control.
DO NOT EXCEED two (2) terminating jumpers on any of the 4 branches of the AEDBHR or the main Alarm Engine bus.

Like the Main Alarm Engine Bus, the Maximum wire length of any of the 4 branches on the AEDBHR is 4000 ft.

Min. wire gauge: 24 AWG 18 to 22 AWG is best for long distances.

